



# FERROBREERO SUMINISTROS INDUSTRIALES

FERRETERÍA EN GENERAL HERRAMIENTAS Y ACCESORIOS PARA METALMECANICA

---

ENERGEX STANLEY Skarpes FOLAMEX Atlas & Mitooyo Jacobs SKENID      y CASTELLÓ

Carr. 12 # 8 - 25 Barrio el Prado / Funza Tel. 823 1277 Cel. 3228358802





PRENSA GIRATORIA



BRIDAS



PRENSA INCLINACION



MESA HORIZONTAL



MESA HORIZONTAL



DIVISOR





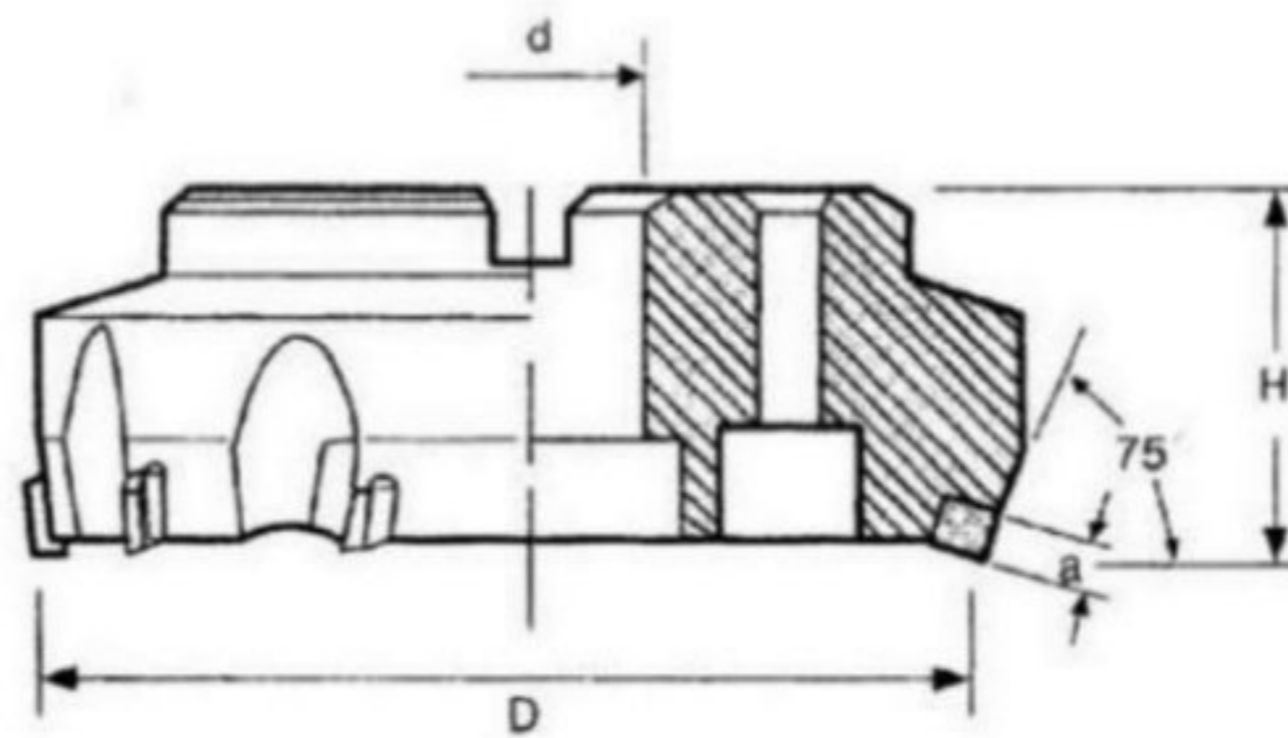

**FRESA PLANEADORA 75º**



**FRESA PLANEADORA 90º**



**PORTA LAMA**



**LAMA**

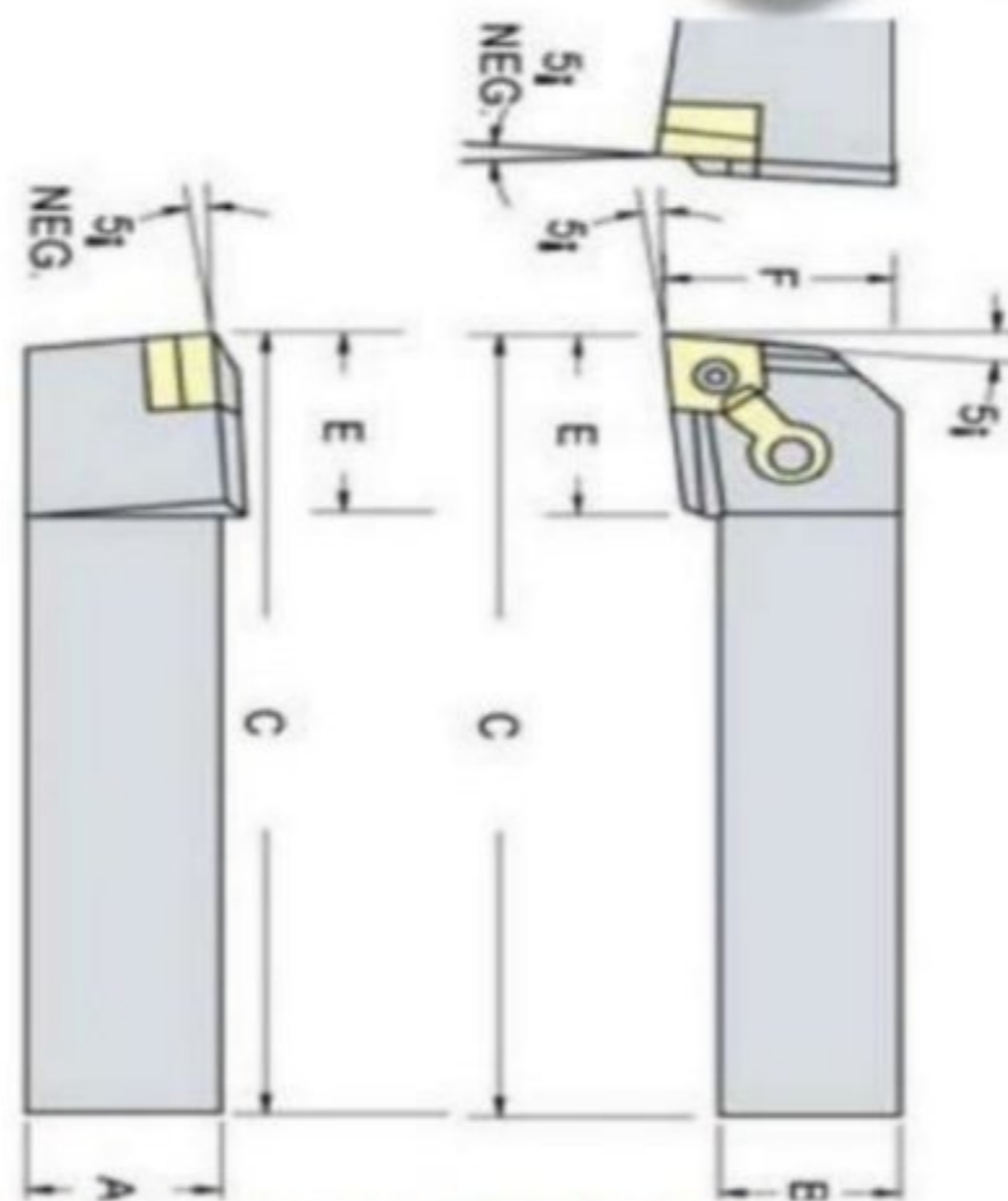

**PORTA INSERTO  
 DERCHO IZQUIERDO**

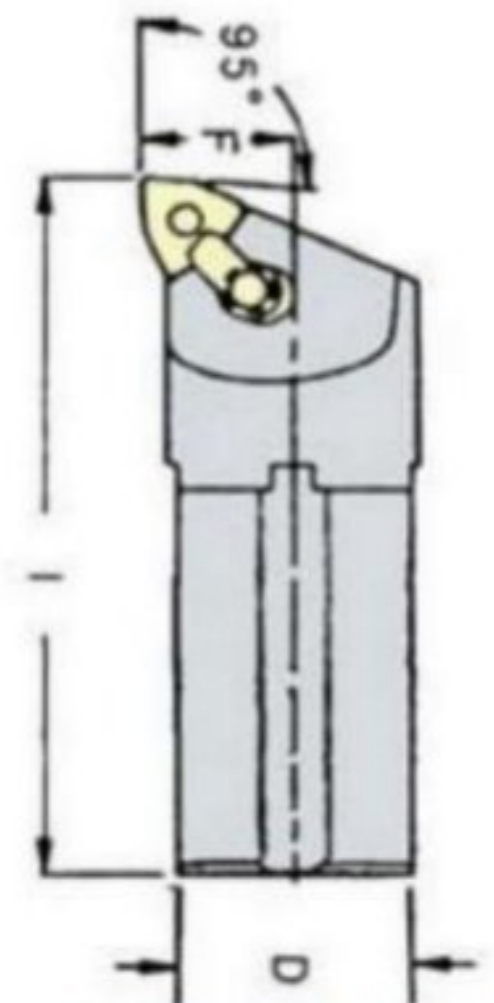
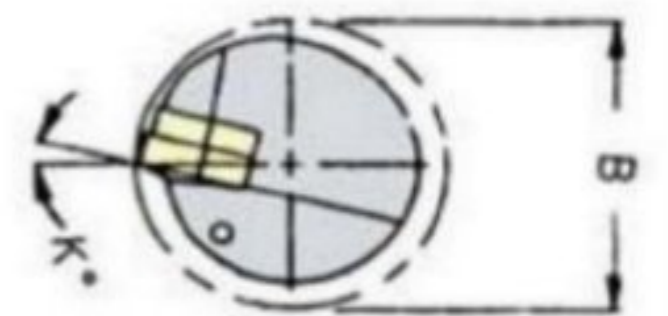

almacen\_ferrobrero@hotmail.com **¡envíanos tu cotización!**





BOQUILLA OZ25



ARBOL PORTA BOQUILLA RECTO



TUERCAS PA ARBOLES ISO



LLAVES P/BOQUILLAS



MORSE



BOQUILLA SC



NT30-ER



ARBOLES P/PLANEADORA



CAT 40



almacen\_ferrobrero@hotmail.com ¡envíanos tu cotización!





**LLAVES PORTA BOQUILLAS Y TUERCAS ER-32**



**CONO MORSE**

- 2X2
- 2X3
- 2XJ33
- 2X6
- 3X2
- 3X3
- 3XJ33
- 3X4
- 3X6
- 4X2
- 4X3
- 4X4
- 4X5
- 5X3
- 5X4
- 5X5

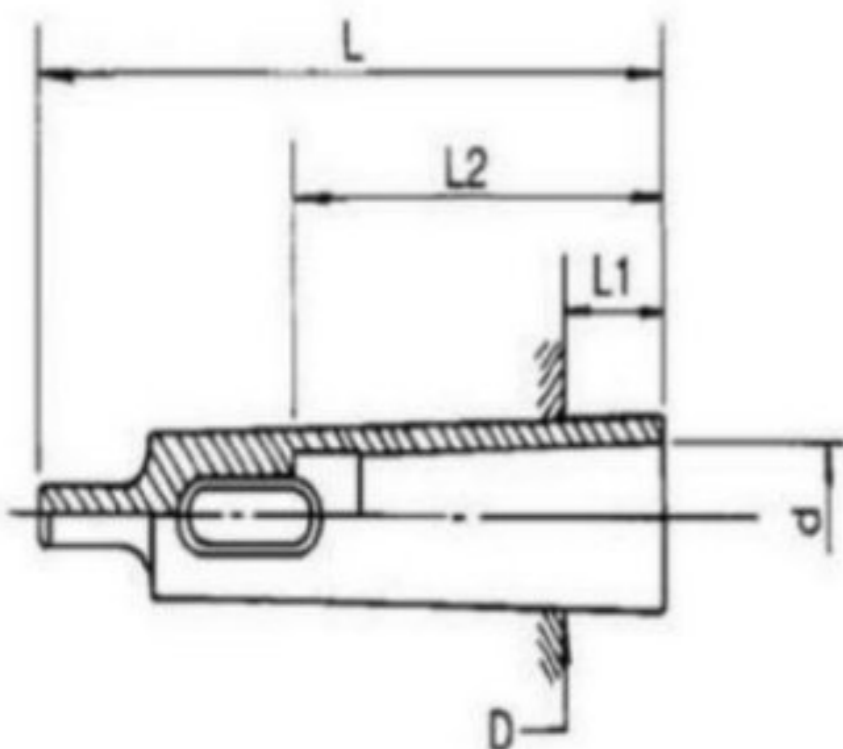

**CONO REDUCCION**

Description						
ORDER NO.	ID.*O.D.	D	d	L	L1	L2
VQ-101	MT2xMT3	23.825	17.780	112	18	67
VQ-102	MT2xMT4	31.267	17.780	124	6.5	67
VQ-103	MT2xMT5	44.399	17.780	156	6.5	67
VQ-105	MT3xMT4	31.267	23.825	140	22.5	84
VQ-106	MT3xMT5	44.399	23.825	156	6.5	84
VQ-107	MT3xMT6	63.348	23.825	218	8	84
VQ-108	MT4xMT5	44.399	31.627	171	21.5	107
VQ-109	MT4xMT6	63.348	31.627	218	8	107
VQ-110	MT5xMT6	63.348	44.399	218	8	133



**CONO MORSE**





### Description

ORDER NO.	Table Slot	SIZE	Gross Weight	Meas.CFT	CODE NO.	Inquiry
CK-103A	7/16"	3/8"-16w	6.7	(C)0.8	1003-009	Inquiry
CK-103B	1/2"	3/8"-16w	6.7	(C)0.8	1003-010	Inquiry
CK-104A	9/16"	1/2"-12w / 1/2"-13UNC	9.7	(C)1.0	1003-011	Inquiry
CK-104B	5/8"	1/2"-12w / 1/2"-13UNC	10.4	(C)1.0	1003-012	Inquiry
CK-105A	11/16"	5/8"-11w	12.5	(C)1.5	1003-013	Inquiry

ORDER NO.	ACTUAL SIZE	LENGTH	HOLE SIZE	CENTER DISTANCE	HOLE DIA.	OFFSET	WEIGHT	CODE NO.	Inquiry
VBC-2(m)	50	62	15	12	15	0.8	3401-302	Inquiry	
VBC-3(m)	75	80	23	18	25	2	3401-304	Inquiry	
VBC-4(m)	100	90	32	25	25	4	3401-306	Inquiry	



## BRIDAS

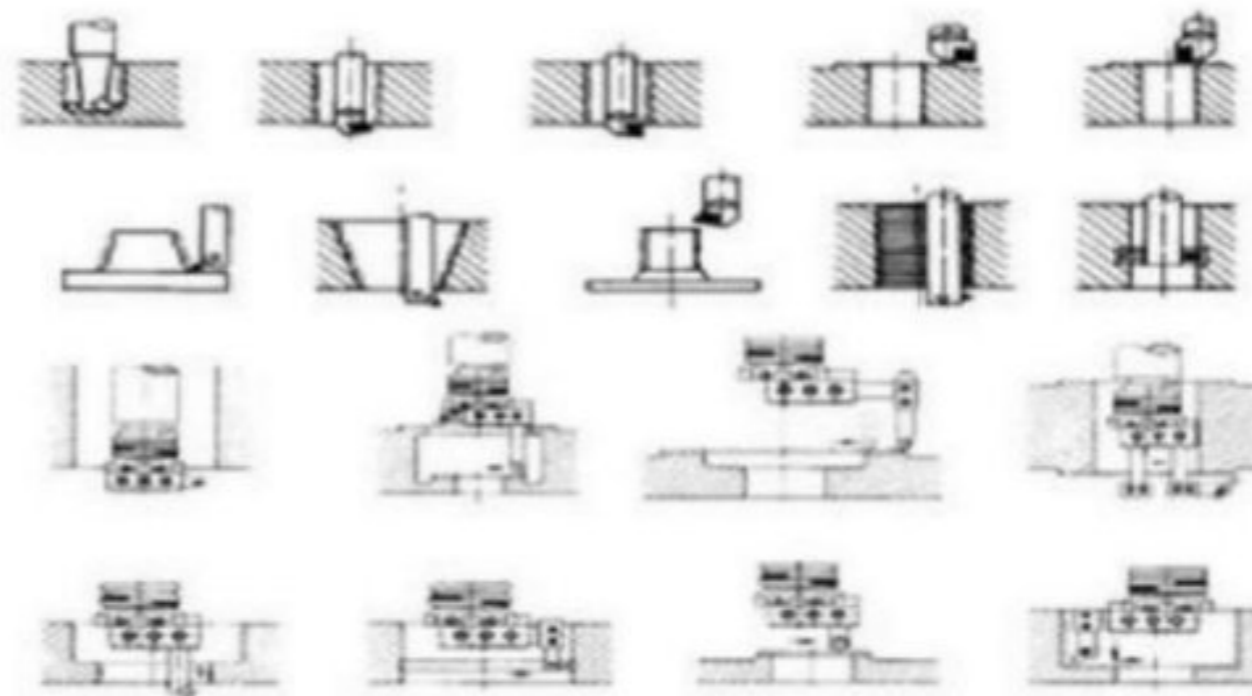
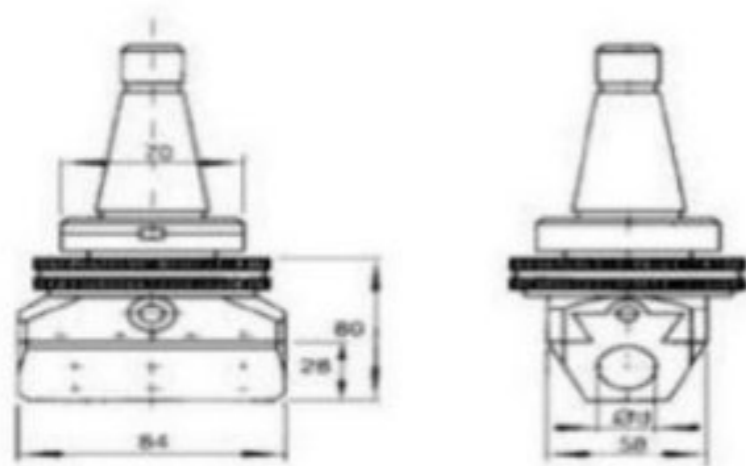

almacen\_ferrobrero@hotmail.com [¡envíanos tu cotización!](#)











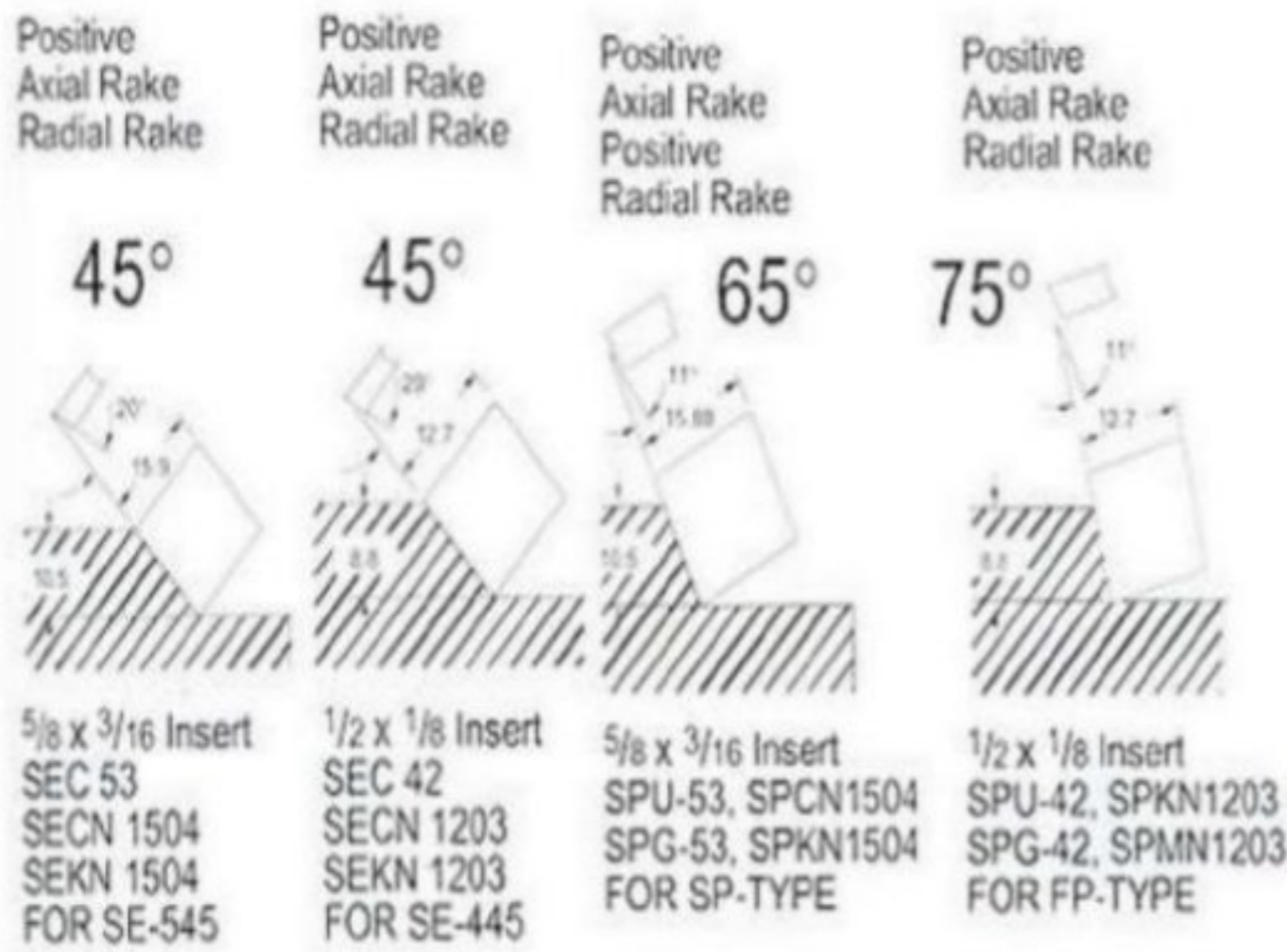

Positive Axial Rake

90°



1/4 x 3/32 Insert  
 TPG-21  
 TPMN1102  
 FOR SAE-TYPE

Positive Axial Rake

90°

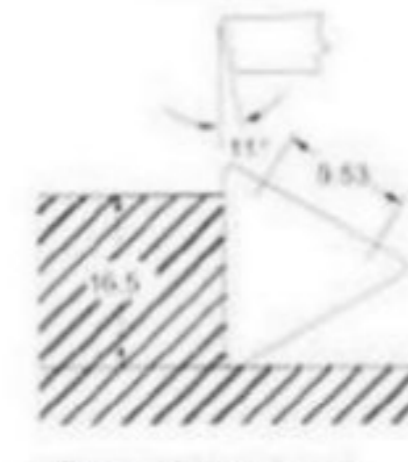

3/8 x 1/8 Insert  
 TPU-32  
 TPG-32  
 TPMN1603  
 TPCN1603  
 FOR SAE-TYPE

Positive Axial Rake Radial Rake

90°

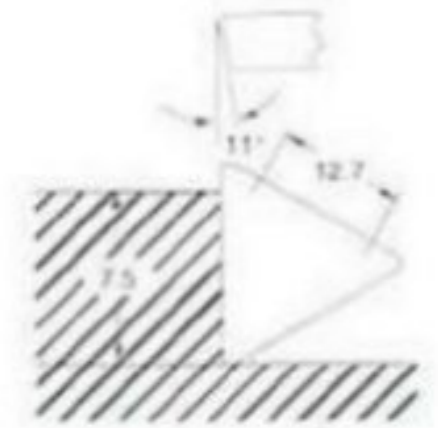

1/2 x 3/16 Insert  
 TPk-43  
 TPKN2204  
 TPMN2204  
 FOR TP-TYPE



Description

ORDER NO.	L	CAPA CITY	d4	DESCRIPTION	CODE NO.	Inquiry
FC-10	11	d 2.5-4.5 mm	16	FLEX COLLET	3404-030	Inquiry
FC-11	11	d 4.5-6.5 mm	16	FLEX COLLET	3404-031	Inquiry
FC-20	13	d 4.5-7.5 mm	21.5	FLEX COLLET	3404-032	Inquiry
FC-21	13	d 7.5-10 mm	21.5	FLEX COLLET	3404-033	Inquiry
FC-30	15	d 8-16 mm	26.5	FLEX COLLET	3404-034	Inquiry
FC-31	15	d 14-19 mm	26.5	FLEX COLLET	3404-035	Inquiry



Description

ORDER NO.	D	d1	d2	L	l1	l2	WEIGHT
VPS-20B	Ø20	18	10	160	79	41	0.4 kg



Description



02-2503	02	3100-101	30
02-2504	02	3100-102	40
02-2505	02	3100-103	50
02-2506	02	3100-104	60
02-2507	02	3100-105	70
02-2508	02	3100-106	80
02-2509	02	3100-107	90
02-2510	02	3100-108	10
02-2511	02	3100-109	11
02-2512	02	3100-110	12
02-2513	02	3100-111	13
02-2514	02	3100-112	14
02-2515	02	3100-113	15
02-2516	02	3100-114	16
02-2517	02	3100-115	17
02-2518	02	3100-116	18
02-2519	02	3100-117	19
02-2520	02	3100-118	20
02-2520	02	3100-118	20

02-2521	02	3100-119	21
02-2522	02	3100-120	22
02-2523	02	3100-121	23
02-2524	02	3100-122	24
02-2525	02	3100-123	25
02-2526	02	3100-124	18"
02-2527	02	3100-125	De 3/16"
02-2528	02	3100-126	1/4"
02-2529	02	3100-127	5/16"
02-2530	02	3100-128	3/8"
02-2531	02	3100-129	7/16"
02-2532	02	3100-130	1/2"
02-2533	02	3100-131	9/16"
02-2534	02	3100-132	5/8"
02-2535	02	3100-133	11/16"
02-2536	02	3100-134	3/4"
02-2537	02	3100-135	13/16"
02-2538	02	3100-136	15/16"
02-2539	02	3100-137	1 1/16"
02-2540	02	3100-138	1"



MESA MAGNETICA

Permanent magnetic force.

• Operation plane, specially treated, nondeformation and high precision.

ORDER NO.	SIZE	CHUCKING SIZE				CHUCK MOUNTING FACE			SWITCH TYPE
		A	B	C	D	G	E	F	
VG-407	100x175	100	175	145	20	100	187	15	LIVING HEXAGON SOCKET SCREW KEYS
VG-510	125x250	125	250	206		125	262		
VG-612	150x300	150	300	256		318			
VG-614	150x350		350	306		150	368		
VG-618	150x450	450	406	468					
VG-816	200x400	200	400	356		418	468		
VG-818	200x450		450	406		200	468		
VG-820	200x500		500	456		518			
VG-1020	250x500	250	500	456		250	518		
VG-606	150x150	150	150	116		150	162		
VG-1224	300x600	300	600	550	18	300	620		









Description

ORDER NO.	CAPA CITY	SHANK	WEIGHT	PACKING	SPEED
K1-1/2	Ø3-8mm	1/2"	0.8KG	90x90x190	1 : 1
K1-MT2	Ø3-8mm	MT-2	1KG	90x90x240	1 : 1
K2-1/2	Ø5-10mm	1/2"	1.5KG	100x100x210	1 : 1
K2-MT2	Ø5-10mm	MT-2	1.6KG	100x100x260	1 : 1
K3-MT3	Ø6-14mm	MT-3	3.1KG	125X125X300	1 : 1
K4-MT3	Ø12-25mm	MT-3	5.4KG	160x160x360	1 : 1



**ROSCADORES**

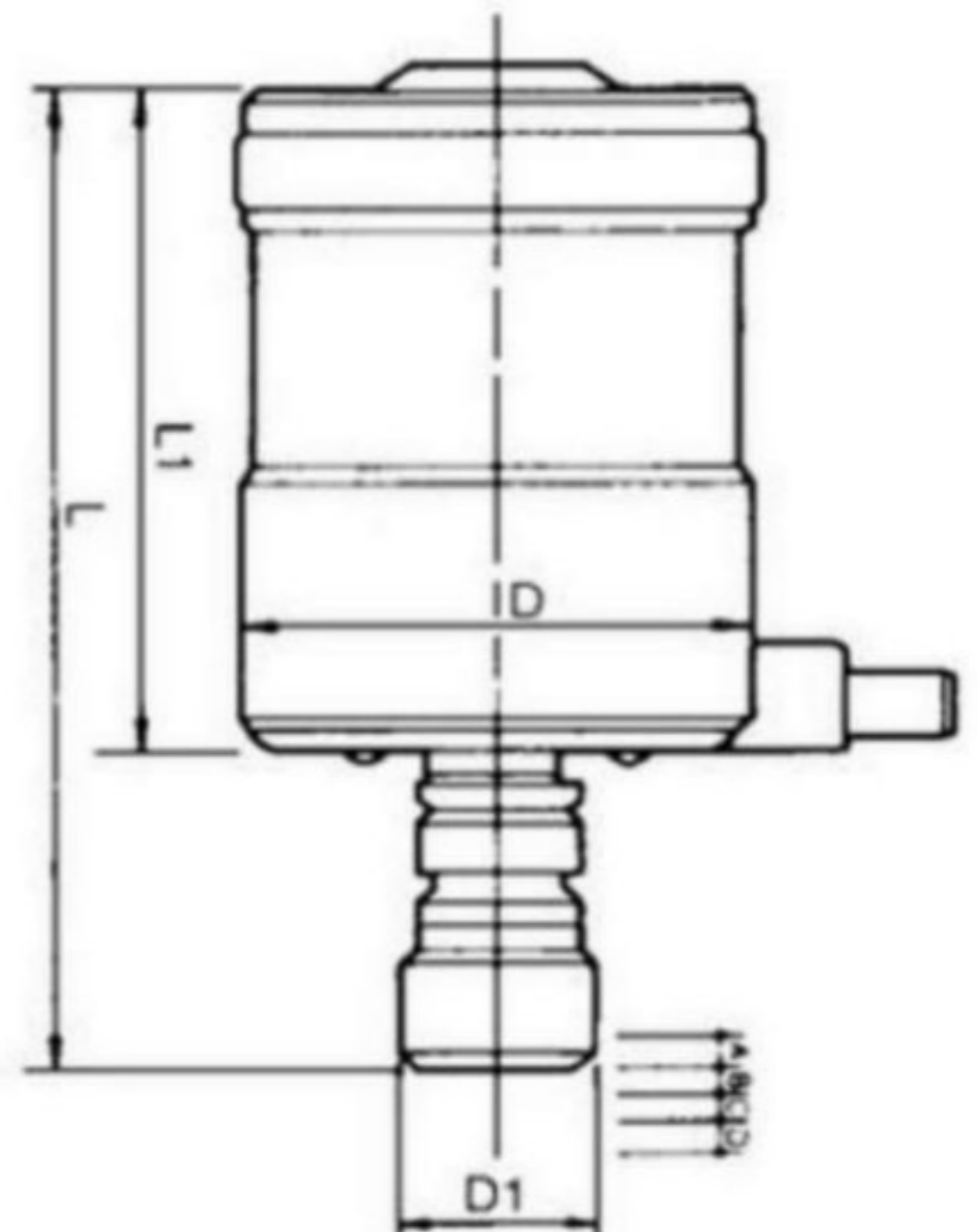

almacen\_ferrobrero@hotmail.com **¡envíanos tu cotización!**





### Avellanadores 6 Filos

ACERO ALTA VELOCIDAD

Díametro de Corte	Díametro del Mango	90° Código	82° Código	90° Código
3/16	3/16	5-600-8005	5-600-8205	5-600-9005
1/4	1/4	5-600-8010	5-600-8210	5-600-9010
5/16	1/4	5-600-8015	5-600-8215	5-600-9015
3/8	1/4	5-600-8020	5-600-8220	5-600-9020
1/2	1/4	5-600-8025	5-600-8225	5-600-9025
5/8	1/2	5-600-8030	5-600-8230	5-600-9030
3/4	1/2	5-600-8035	5-600-8235	5-600-9035
7/8	1/2	5-600-8040	5-600-8240	5-600-9040
1	1/2	5-600-8045	5-600-8245	5-600-9045
1-1/4	3/4	5-600-8050	5-600-8250	5-600-9050
1-1/2	3/4	5-600-8055	5-600-8255	5-600-9055
1-3/4	1	5-600-8060	5-600-8260	5-600-9060
2	1	5-600-8065	5-600-8265	5-600-9065
Juego de 5 piezas 1/4-1"		5-600-8085	5-600-8285	5-600-9085
Juego de 6 piezas 1/4-1"		-	5-600-8290	-
Juego de 8 piezas 1/4-1"		5-600-8288	5-600-8288	5-600-9088
Juego de 10 piezas 1/4-1-1/2"		5-600-8290	5-600-8290	5-600-9090
Juego de 11 piezas 3/16 to 1-1/2"		5-600-8291	5-600-8291	5-600-9091



### Fresas (Cortadores) Verticales Desbaste



### Estándar Americano

Ancho de Culetero B	Tolerancias	Brocha Dimensiones		Calzos Usados	Largo de Corte		Código
		B1	L		Minimo	Maximo	
1/16-AA	.0025-.0035			0			5-808-001R
3/32-AA	.0038-.0048	1/8	5	0	13/64	1-1/8	5-808-002R
1/8-AA	.1252-.1262			1			5-808-003R
3/32-BB	.0038-.0048			0			5-808-004R
1/8-BB	.1252-.1262	3/16	6-3/4	1	19/64	1-11/16	5-808-005R
5/32-BB	.1564-.1574			1			5-808-006R
3/16-BB	.1877-.1887			1			5-808-007R
3/16-CC	.1877-.1887			1			5-808-008R
1/4-CC	.2502-.2512	3/8	11-3/4	1	25/64	2-1/2	5-808-009R
5/16-CC	.3127-.3137			2			5-808-010R
3/8-CC	.3755-.3765			2			5-808-011R
5/16-DD	.3127-.3137			2			5-808-012R
3/8-DD	.3755-.3765	9/16	13-7/8	2	1	6	5-808-013R
7/16-DD	.4380-.4390			3			5-808-014R
1/2-DD	.5006-.5016			3			5-808-015R
5/8-EE	.6260-.6270	3/4	15-1/2	4	1	6	5-808-016R
3/4-EE	.7515-.7525			5			5-808-017R
7/8-FF	.8767-.8775	1	20-1/4	6	1	6	5-808-018R
1-FF	1.0015-1.0025			7			5-808-019R



Diá. de Fresa	Diá. de Mango	Largo de Corte	No. de Filos	Largo Total	Código Dolia
1/4	3/8	5/8	4	2-7/16	5-431-005
5/16	3/8	3/4	4	2-1/2	5-431-010
3/8	3/8	3/4	4	2-1/2	5-431-015
7/16	3/8	1	4	2-3/4	-
1/2	1/2	1-1/4	4	3-1/4	5-431-020*
1/2	1/2	2	4	4	5-431-025
9/16	1/2	1-3/8	4	3-3/8	-
5/8	5/8	1-5/8	4	3-3/4	5-431-030*
5/8	5/8	2-1/2	4	4-5/8	-
11/16	5/8	1-5/8	4	3-3/4	-
3/4	5/8	1-5/8	4	3-3/4	5-431-035
3/4	3/4	1-5/8	4	3-3/4	5-431-040*
3/4	3/4	1-5/8	4	3-7/8	-
3/4	5/8	3	4	5-1/8	5-431-045
3/4	3/4	3	4	5-1/4	5-431-050
13/16	3/4	1-7/8	4	4	-
7/8	3/4	1-7/8	5	4-1/8	5-431-055
7/8	3/4	3-1/2	5	5-5/8	5-431-060
7/8	7/8	1-7/8	4	4-1/8	-
7/8	7/8	3-1/2	4	5-3/4	-
15/16	3/4	1-7/8	4	4-1/8	-
1	1	2	5	4-1/2	5-431-065
1	3/4	2	5	4-1/2	5-431-070*
1	1	3	5	5-1/2	-
1	1	4	5	6-1/2	5-431-075



almacen\_ferrobrero@hotmail.com [envíanos tu cotización!](#)



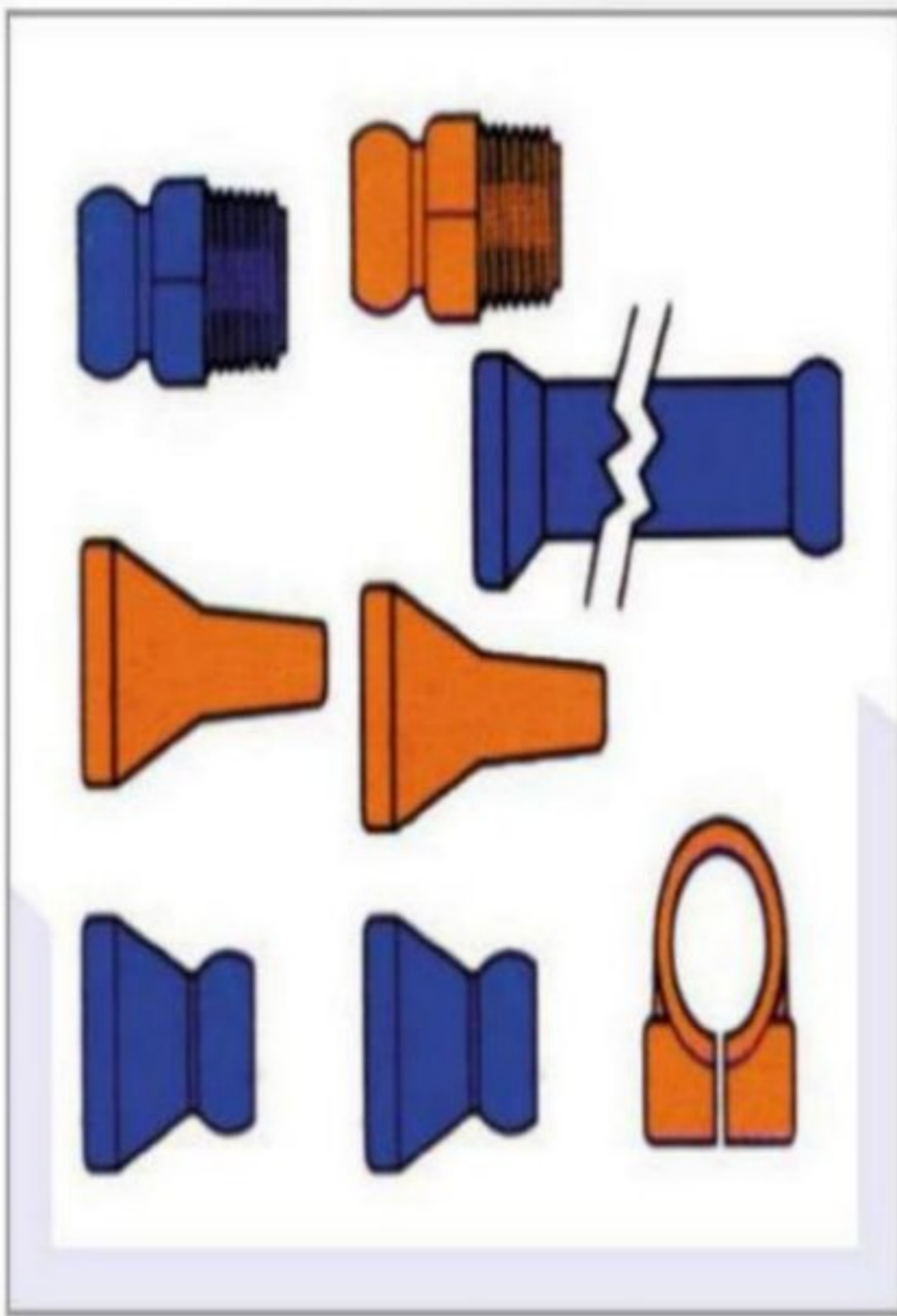

**FIGURE ITEM NO. DESCRIPTION**

- 
**82020** 1/4" Hose Kit  
33 CM Length with Fittings  
2-14 CM Segments  
1/16", 1/8", 1/4" Nozzles  
1/4" & 1/8" Male PT  
connectors  
CODE NO.2019-101
- 
**82020A** 1/4" Hose Kit  
33 CM Length with Fittings  
2-14 CM Segments  
1/16", 1/8", 1/4" Nozzles  
1/4" & 1/8" Male NPT  
connectors  
CODE NO.2019-102
- 
**82020** 1/4" Extension Element Kit  
with Element Clamps  
includes 4 each of:  
1/4" Extended Elements  
1/4" Element Clamps  
CODE NO.2019-103
- 
**82021** 1/4" Segment pack  
(2-14CM 20pcs) CODE NO.2019-104
- 
**82051** 1/4" 1524 CM coil  
CODE NO.2019-10-2
- 
**82071** 1/4" 2500 CM coil  
CODE NO.2019-10-3  
Weight: 0.09177kg
- 
**82423** 1/4" Circle Flow Nozzle Kit  
Assembled with 15 Side  
Flow Nozzles 1/4" &  
1 End Cap 1/4"  
CODE NO.2019-105
- 
**82221** 1/4" Extended Elements,  
pack of 4 CODE NO.2019-108
- 
**82241** 1/4" Extended Elements,  
pack of 20 CODE NO.2019-107  
Weight: 0.03641kg
- 
**82222** 1/4" Element Clamps,  
pack of 4 CODE NO.2019-109
- 
**82242** 1/4" Element Clamps,  
pack of 20 CODE NO.2019-110  
Weight: 0.03269kg

**FIGURE ITEM NO. DESCRIPTION**

- 
**82225** 1/4" 90° Nozzles,  
pack of 4 CODE NO.2019-121
- 
**82245** 1/4" 90° Nozzles,  
pack of 20 CODE NO.2019-120  
Weight: 0.00239kg
- 
**82226** 1/4" 90° Spray Bar  
Nozzles, pack of 2  
CODE NO.2019-123
- 
**82246** 1/4" 90° Spray Bar  
Nozzles, pack of 20  
CODE NO.2019-124  
Weight: 0.00289kg
- 
**82017** 3/8" Flat Nozzles,  
pack of 2 CODE NO.2019-125
- 
**82037** 3/8" Flat Nozzles,  
pack of 20 CODE NO.2019-126  
Weight: 0.00302kg
- 
**82027** 1" Flare Nozzles,  
pack of 2 CODE NO.2019-127
- 
**82047** 1" Flare Nozzles,  
pack of 20 CODE NO.2019-128  
Weight: 0.00358kg
- 
**82025** 1/8" PT Connectors  
pack of 4 CODE NO.2019-129
- 
**82035** 1/8" PT Connectors  
pack of 50 CODE NO.2019-130  
Weight: 0.00232kg
- 
**82025A** 1/8" NPT Connectors  
pack of 4 CODE NO.2019-131
- 
**82035A** 1/8" NPT Connectors  
pack of 50 CODE NO.2019-132  
Weight: 0.00232kg
- 
**82026** 1/4" PT Connectors  
pack of 4 CODE NO.2019-133
- 
**82036** 1/4" PT Connectors  
pack of 50 CODE NO.2019-134  
Weight: 0.00259kg
- 
**82026A** 1/4" NPT Connectors  
pack of 4 CODE NO.2019-135
- 
**82036A** 1/4" NPT Connectors  
pack of 50 CODE NO.2019-136  
Weight: 0.00267kg
- 
**82028** 1/4" Y Fitting Pack of 2  
CODE NO.2019-137
- 
**82038** 1/4" Y Fitting Pack of 20  
CODE NO.2019-138  
Weight: 0.00269kg
- 
**82011** 1/4" Double Sockets,  
pack of 4 CODE NO.2019-139
- 
**82031** 1/4" Double Sockets,  
pack of 20 CODE NO.2019-140  
Weight: 0.00173kg

**FIGURE ITEM NO. DESCRIPTION**

- 
**82424** 1/4" End Caps,  
pack of 4 CODE NO.2019-141
- 
**82444** 1/4" End caps,  
pack of 20 CODE NO.2019-142  
Weight: 0.00191kg
- 
**82228** 1/4" Saver Nozzle 40,  
pack of 2 CODE NO.2019-143
- 
**82248** 1/4" Saver Nozzle 40,  
pack of 20 CODE NO.2019-144  
Weight: 0.00815kg
- 
**82229** 1/4" Saver Nozzle 60,  
pack of 2 CODE NO.2019-145
- 
**82249** 1/4" Saver Nozzle 60,  
pack of 20 CODE NO.2019-146  
Weight: 0.00845kg
- 
**82721** 1/4" NPT Male Hose Nipple  
Valves pack of 2  
CODE NO.2019-148
- 
**82731** 1/4" NPT Male Hose Nipple  
Valves pack of 10  
CODE NO.2019-149  
Weight: 0.0079kg
- 
**82521** Acid Resistant  
1/4" NPT Male Hose Nipple  
Valves pack of 2  
CODE NO.2019-150
- 
**82531** 1/4" NPT Male Hose Nipple  
Valves pack of 10  
CODE NO.2019-151  
Weight: 0.00775kg
- 
**82722** 1/4" Connection Valves,  
pack of 2 CODE NO.2019-152
- 
**82732** 1/4" Connection Valves,  
pack of 10 CODE NO.2019-153  
Weight: 0.00803kg
- 
**82522** Acid Resistant  
1/4" Connection Valves,  
pack of 2 CODE NO.2019-154
- 
**82532** 1/4" Connection Valves,  
pack of 14 CODE NO.2019-155  
Weight: 0.00702kg
- 
**82723** 1/4" Male NPT Valves,  
pack of 2 CODE NO.2019-156
- 
**82733** 1/4" Male NPT Valves,  
pack of 10 CODE NO.2019-157  
Weight: 0.0076kg
- 
**82523** Acid Resistant  
1/4" Male NPT Valves,  
pack of 2 CODE NO.2019-158
- 
**82533** 1/4" Male NPT Valves,  
pack of 10 CODE NO.2019-159  
Weight: 0.00776kg
- 
**82724** 1/4" Female NPT Valves,  
pack of 2 CODE NO.2019-160
- 
**82744** 1/4" Female NPT Valves,  
pack of 10 CODE NO.2019-161

- 
**82224** 1/8" 90° Nozzles,  
pack of 4 CODE NO.2019-118
- 
**82244** 1/8" 90° Nozzles,  
pack of 20 CODE NO.2019-119  
Weight: 0.00183kg
- 
**82524** Acid Resistant  
1/4" Female NPT Valves,  
pack of 2 CODE NO.2019-162
- 
**82534** 1/4" Female NPT Valves,  
pack of 10 CODE NO.2019-163  
Weight: 0.00808kg
- 
**82725** 1/4" Connection Check  
Valves pack of 2  
CODE NO.2019-164
- 
**82745** 1/4" Connection Check  
Valves pack of 10  
CODE NO.2019-165  
Weight: 0.00802kg
- 
**82022** 1/16" Round Nozzles  
Pack of 4 CODE NO.2019-115
- 
**82042** 1/16" Round Nozzles  
Pack of 50 CODE NO.2019-112  
Weight: 0.00198kg
- 
**82023** 1/8" Round Nozzles  
Pack of 4 CODE NO.2019-113
- 
**82043** 1/8" Round Nozzles  
Pack of 50 CODE NO.2019-114  
Weight: 0.00198kg
- 
**82024** 1/4" Round Nozzles  
Pack of 4 CODE NO.2019-116
- 
**82044** 1/4" Round Nozzles  
Pack of 50 CODE NO.2019-117  
Weight: 0.00208kg
- 
**82223** 1/16" 90° Nozzles,  
pack of 4 CODE NO.2019-117
- 
**82243** 1/16" 90° Nozzles,  
pack of 20 CODE NO.2019-118  
Weight: 0.00198kg



**BASE MAGNETICA**

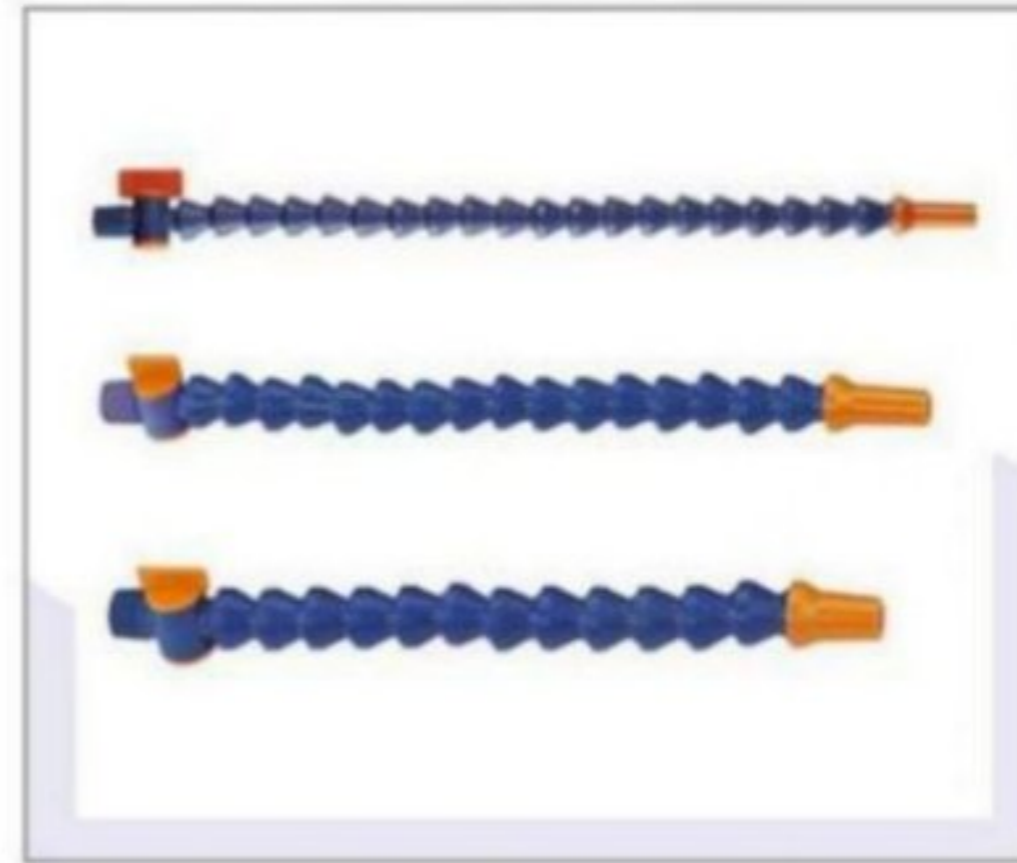

**MANGUERA**





### Calibradores Pies de Rey "Vernier"

Acero Inoxidable de Precisión y Cromo Satinado



### Micrómetros de Exteriores

Con Puntas de Contacto en Carburo

Inglés - 0.0001"

Rango	Graduación	Código
0-1"	.0001"	2-228-001
1-2"	.0001"	2-228-002
2-3"	.0001"	2-228-003
3-4"	.0001"	2-228-004
4-5"	.0001"	2-228-005
5-6"	.0001"	2-228-006
6-7"	.0001"	2-228-007
7-8"	.0001"	2-228-008
8-9"	.0001"	2-228-009
9-10"	.0001"	2-228-010
10-11"	.0001"	2-228-011
11-12"	.0001"	2-228-012

### Métrico - 0.01mm

Rango	Código
0-25 mm	2-248-001
25-50 mm	2-248-002
50-75 mm	2-248-003
75-100 mm	2-248-004
100-125 mm	2-248-005
125-150 mm	2-248-006
150-175 mm	2-248-007
175-200 mm	2-248-008
200-225 mm	2-248-009
225-250 mm	2-248-010
250-275 mm	2-248-011
275-300 mm	2-248-012

### Micrómetros para Interiores

#### Métrico

Rango	Graduación	Código
5-30 mm	0.01 mm con estándar	2-275-101
30-55 mm	0.01 mm con estándar	2-275-102

#### Inglés

Rango	Graduación	Código
0.2 - 1.2"	0.001" con estándar	2-239-001
1.2 - 2.2"	0.001" con estándar	2-275-002







Tabla 1. Formas y aplicaciones de las limas rotativas

Cilíndrica	Cilíndrica redonda o con radio	Oval	Forma de árbol con radio
Forma de árbol puntiagudo (Obús)	Llama	Cónica redonda o con radio	Cónica con punta
Esférica o Bola			

Importadores y Distribuidores de Herramientas y Accesorios para Metalmecánica









CALIBRADOR DE ROSCAS

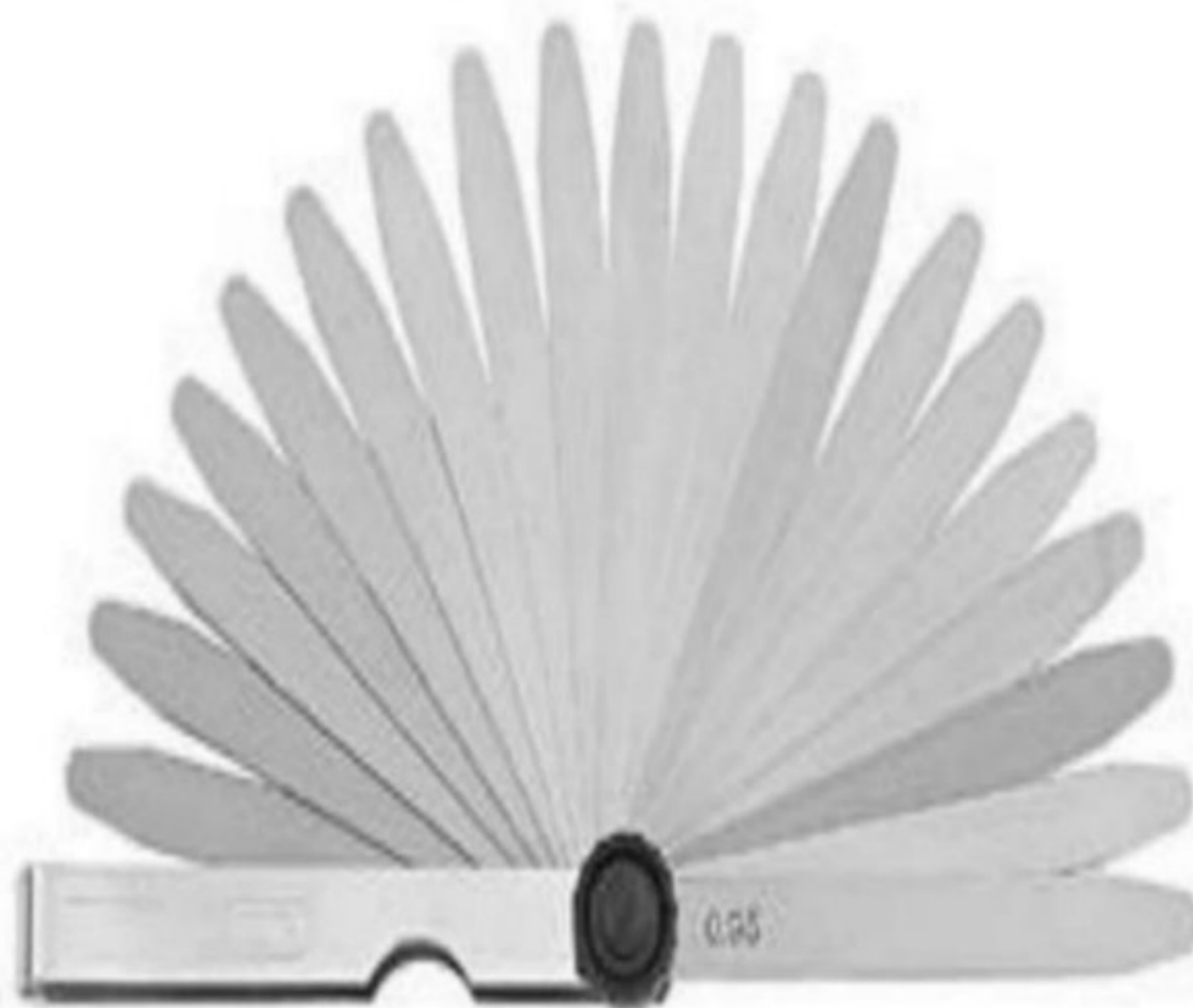

CALIBRADOR P/VALVULAS

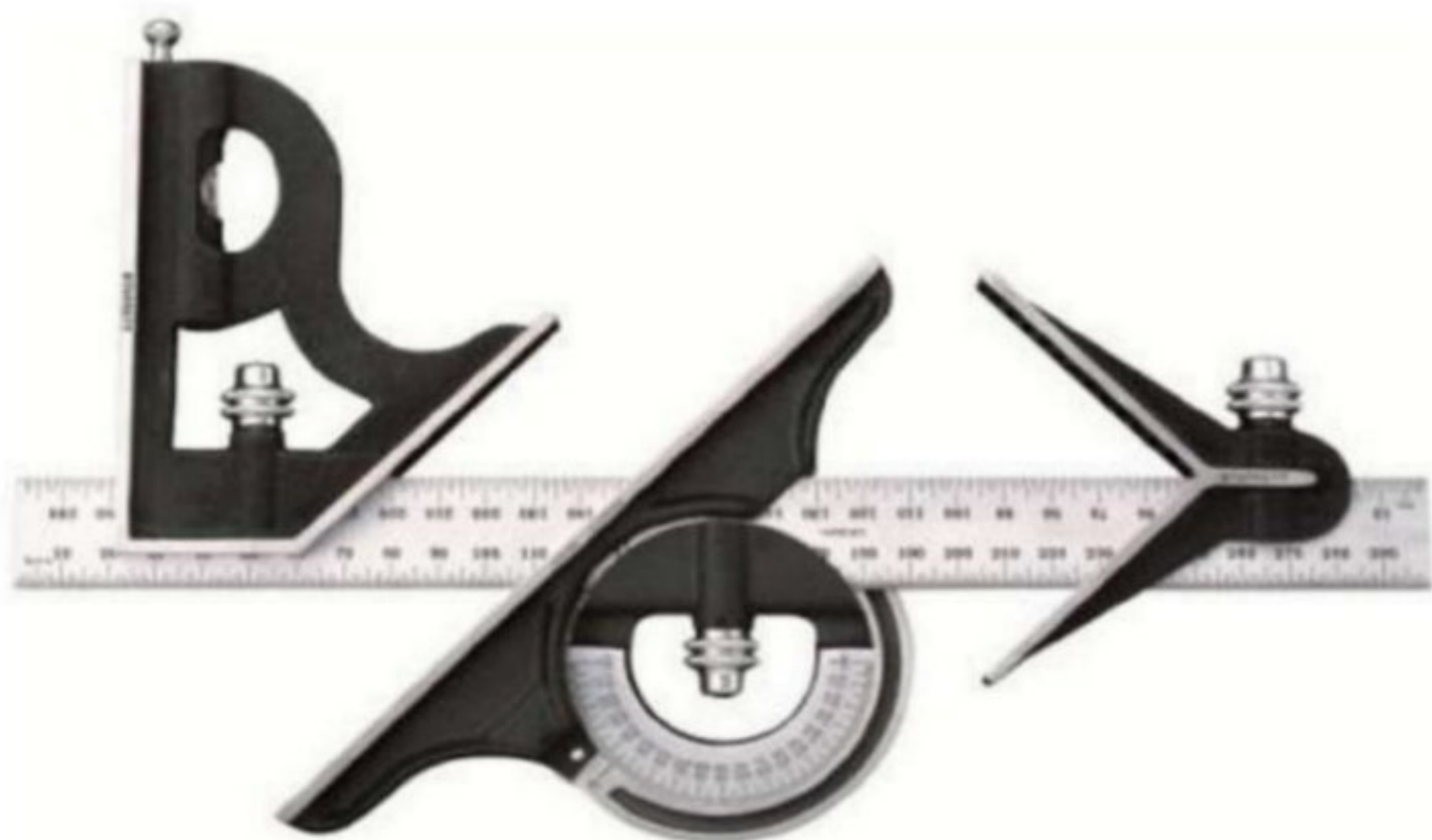

ESCUADRA UNIVERSAL



CALIBRADOR DE ALTURAS



# Escuadras de Acero Templado

## Escuadras Biseladas

El largo de la hoja está medido desde el borde interior de la base hasta el final de la hoja misma.

### Características Especiales

Las escuadras tienen ángulos rectos exactos, correctos en ambos lados interior y exterior.

Las bases y las hojas están endurecidas y rectificadas a un mínimo de 55 HCR y son lapeadas con exactitud para conseguir paralelismo y rectitud.

Las hojas están biseladas en ambos bordes de cada lado.

MKSg

Hoja	Base	Código
1-3/8"	1"	2-426-001
2-3/8"	1-3/8"	2-426-002
3-1/8"	2"	2-426-003
5"	3"	2-426-005
6-3/4"	4"	2-426-006
8-1/2"	5-1/8"	2-426-008
10-1/2"	6-3/8"	2-426-010

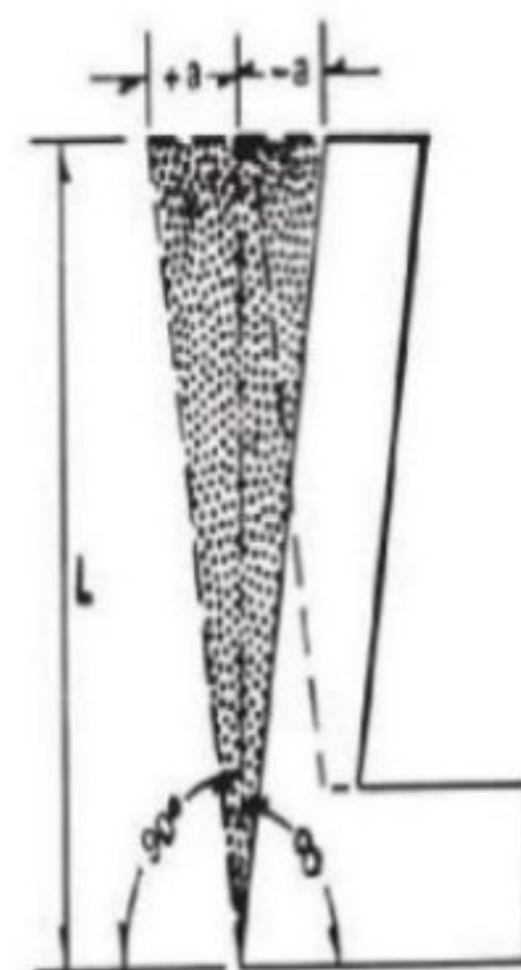



### SH Burs - Flame Shape

D1	L1	D2	L2	Singlecut
1/8	1/4	1/8	1-1/2	SH-41SC*
1/4	1/2	1/4	2	SH-1SC*
1/4	1/2	1/4	6-3/4	SH-1L6SC
5/16	3/4	1/4	2-1/2	SH-2SC
5/16	3/4	1/4	6	SH-2L6SC
1/2	1-1/4	1/4	3	SH-5SC
1/2	1-1/4	1/4	7-1/4	SH-5L6SC
5/8	1-7/16	1/4	3-3/16	SH-6SC
3/4	1-5/8	1/4	3-3/8	SH-7SC

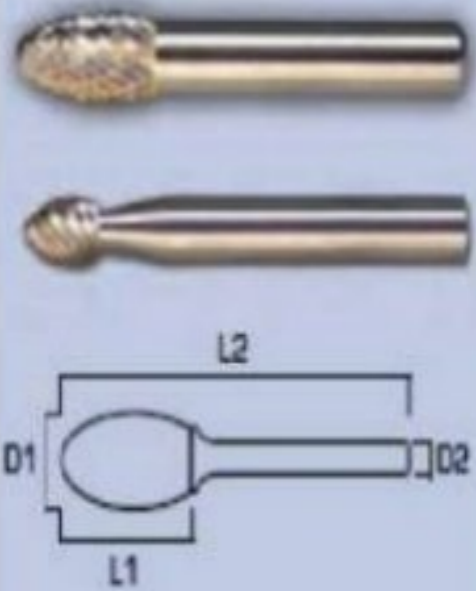

### SL Burs - 14° Included Cone

D1	L1	D2	L2	DEG	Singlecut
1/8	3/8	1/8	1-1/2	8°	SL-41SC*
1/8	1/2	1/8	1-1/2	8°	SL-42SC*
1/4	5/8	1/4	2	14°	SL-1SC*
1/4	5/8	1/4	6-3/4	14°	SL-1L6SC
5/16	7/8	1/4	2-5/8	14°	SL-2SC
3/8	1-1/16	1/4	2-13/16	14°	SL-3SC
3/8	1-1/16	1/4	7-1/16	14°	SL-3L6SC
1/2	1-1/8	1/4	2-7/8	14°	SL-4SC
1/2	1-1/8	1/4	7-1/8	14°	SL-4L6SC
5/8	1-3/16	1/4	2-15/16	14°	SL-5SC
5/8	1-5/16	1/4	3-1/16	14°	SL-6SC
3/4	1-1/2	1/4	3-1/4	14°	SL-7SC

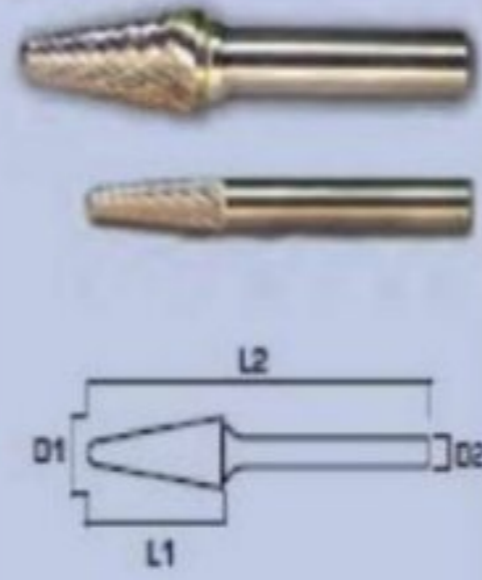

### SM Burs - Pointed Cone Shape

D1	L1	D2	L2	DEG	Singlecut
1/8	11/32	1/8	1-1/2	12°	SM-41SC*
1/8	7/16	1/8	1-1/2	14°	SM-42SC*
1/8	5/8	1/8	1-1/2	7°	SM-43SC*
1/4	1/2	1/8	2-1/8	22°	SM-51SC
1/4	1/2	1/4	2	22°	SM-1SC*
1/4	1/2	1/4	6-3/4	14°	SM-1L6SC
1/4	3/4	1/4	2	14°	SM-2SC
1/4	3/4	1/4	6-3/4	14°	SM-2L6SC
1/4	1	1/4	2	14°	SM-3SC*
3/8	5/8	1/4	2-1/2	14°	SM-4SC
3/8	5/8	1/4	6-5/8	14°	SM-4L6SC
1/2	7/8	1/4	2-5/8	14°	SM-5SC
1/2	7/8	1/4	6-7/8	14°	SM-5L6SC
5/8	1	1/4	2-3/4	14°	SM-6SC

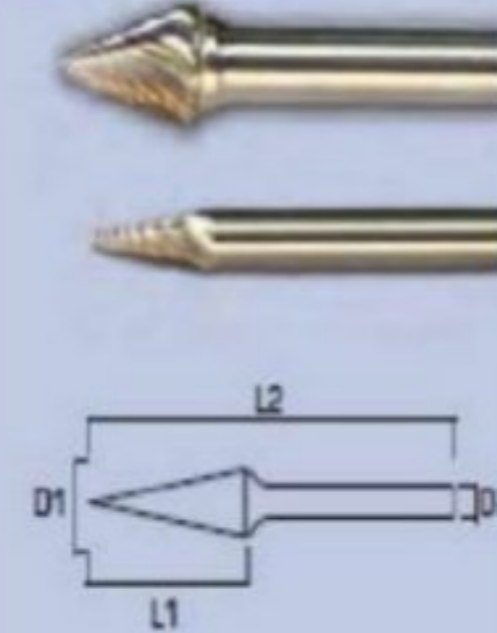

almacen\_ferrobrero@hotmail.com [envíanos tu cotización!](#)



### SC Burs - Radius Cylinder

D1	L1	D2	L2	Singlecut
3/32	7/16	1/8	1-1/2	SC-41SC*
1/8	9/16	1/8	1-1/2	SC-42SC*
1/4	1/2	1/8	2	SC-51SC
1/8	5/8	1/4	2	SC-12SC*
3/16	5/8	1/4	2	SC-14SC*
1/4	5/8	1/4	2	SC-15C*
1/4	5/8	1/4	6-3/4	SC-1L6SC
5/16	3/4	1/4	2-1/2	SC-2SC
3/8	3/4	1/4	2-1/2	SC-3SC
3/8	3/4	1/4	6-3/4	SC-3L6SC
7/16	1	1/4	2-3/4	SC-4SC
1/2	1	1/4	2-3/4	SC-5SC
1/2	1	1/4	7	SC-5L6SC
5/8	1	1/4	2-3/4	SC-6SC
5/8	1	1/4	7	SC-6L6SC
3/4	1	1/4	2-3/4	SC-7SC

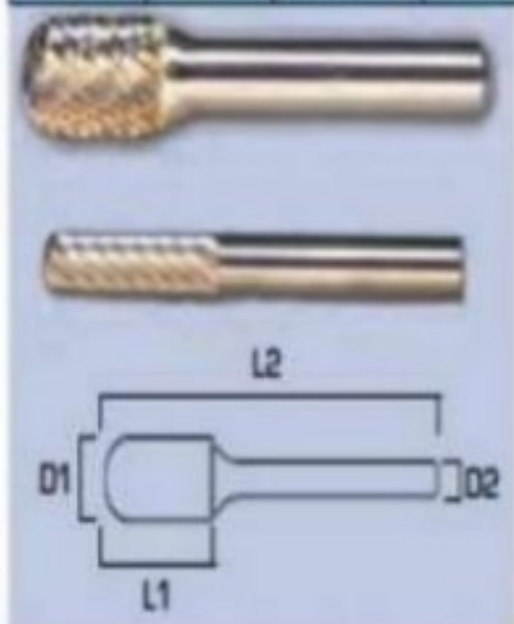

### SB Burs

D1	L1	D2	L2	Singlecut
1/16	1/4	1/8	1-1/2	SB-41SC*
3/32	7/16	1/8	1-1/2	SB-42SC*
1/8	9/16	1/8	1-1/2	SB-43SC*
1/4	3/16	1/8	2-15/16	SB-51SC
1/8	5/8	1/4	2	SB-12SC*
3/16	5/8	1/4	2	SB-14SC*
1/4	5/8	1/4	2	SB-15C*
1/4	5/8	1/4	6-3/4	SB-1L6SC
5/16	3/4	1/4	2-1/2	SB-2SC
3/8	3/4	1/4	2-1/2	SB-3SC
3/8	3/4	1/4	6-3/4	SB-3L6SC
7/16	1	1/4	2-3/4	SB-4SC
1/2	1	1/4	2-3/4	SB-5SC
1/2	1	1/4	7	SB-5L6SC
5/8	1	1/4	2-3/4	SB-6SC
3/4	3/4	1/4	2-1/2	SB-16SC
3/4	1	1/4	2-3/4	SB-7SC
1	1	1/4	2-3/4	SB-9SC

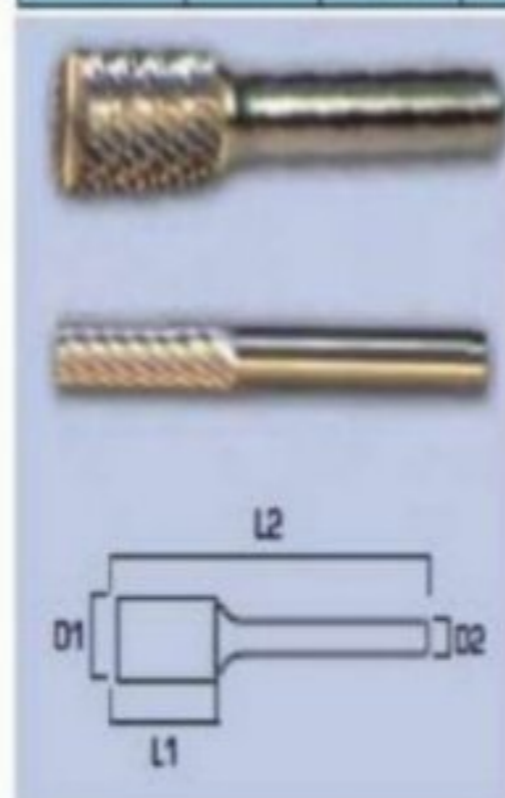

### Bur Cut Types





#### SD Burs - Ball Shape

D1	L1	D2	L2	Singlecut
3/32	3/32	1/8	1-1/2	SD-41SC*
1/8	1/8	1/8	1-1/2	SD-42SC*
1/4	7/32	1/8	13/4	SD-51SC
1/8	3/32	1/4	2	SD-12SC*
3/16	1/8	1/4	2	SD-14SC*
1/4	7/32	1/4	2	SD-15SC*
1/4	7/32	1/4	6-3/4	SD-1L6SC
5/16	1/4	1/4	2-1/16	SD-2SC
3/8	5/16	1/4	2-1/8	SD-3SC
3/8	5/16	1/4	6-3/8	SD-3L6SC
7/16	3/8	1/4	2-3/16	SD-4SC
1/2	7/16	1/4	2-1/4	SD-5SC
1/2	7/16	1/4	6-1/2	SD-5L6SC
5/8	9/16	1/4	2-3/8	SD-6SC
3/4	11/16	1/4	2-1/2	SD-7SC
1	15/16	1/4	2-3/4	SD-9SC

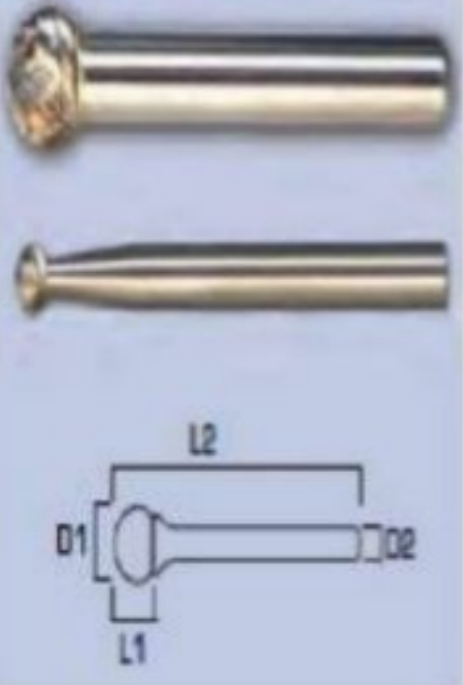

#### SE Burs - Oval Shape

D1	L1	D2	L2	Singlecut
1/8	7/32	1/8	1-1/2	SE-41SC*
1/4	3/8	1/8	13/4	SE-51SC
1/4	3/8	1/4	2	SE-16SC*
1/4	3/8	1/4	6-3/4	SE-1L6SC
3/8	5/8	1/4	2-3/8	SE-3SC
3/8	5/8	1/4	6-5/8	SE-3L6SC
1/2	7/8	1/4	2-5/8	SE-5SC
1/2	7/8	1/4	6-7/8	SE-5L6SC
5/8	1	1/4	2-3/4	SE-6SC
3/4	1	1/4	2-3/4	SE-7SC

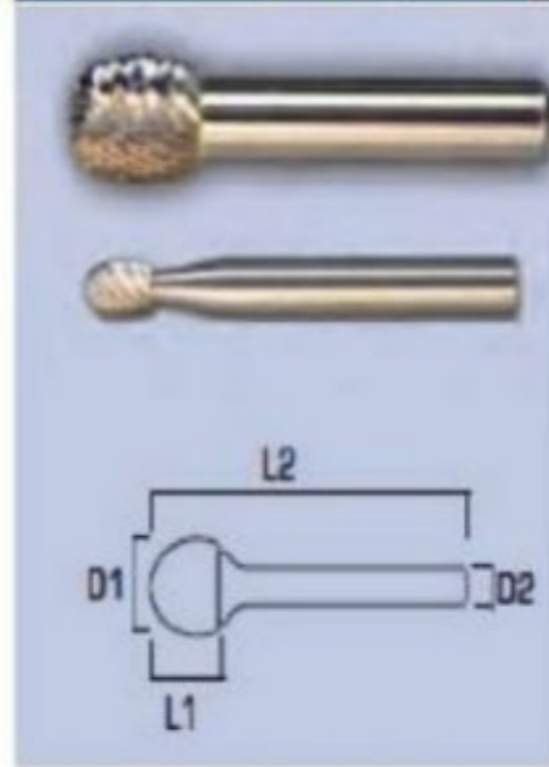

#### SF Burs - Tree Shape

D1	L1	D2	L2	Singlecut
1/8	1/4	1/8	1-1/2	SF-41SC*
1/8	1/2	1/8	1-1/2	SF-42SC*
1/4	1/2	1/8	2	SF-51SC
1/8	1/2	1/4	2	SF-12SC*
1/4	5/8	1/4	2	SF-16SC*
1/4	5/8	1/4	6-3/4	SF-1L6SC
3/8	3/4	1/4	2-1/2	SF-3SC
3/8	3/4	1/4	6-3/4	SF-3L6SC
7/16	1	1/4	2-3/4	SF-4SC
1/2	3/4	1/4	2-1/2	SF-13SC
1/2	1	1/4	2-3/4	SF-5SC
1/2	1	1/4	7	SF-5L6SC
5/8	1	1/4	2-3/4	SF-6SC
3/4	1	1/4	2-3/4	SF-7SC
3/4	1-1/4	1/4	3	SF-14SC
3/4	1-1/2	1/4	3-1/4	SF-15SC

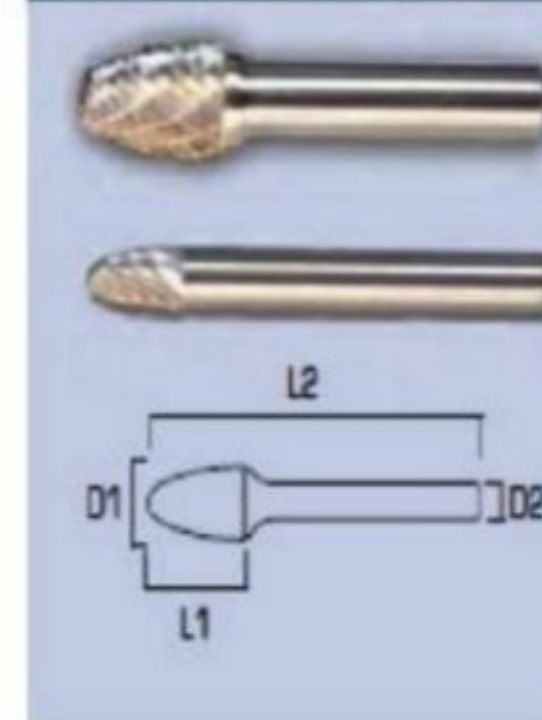

#### SG Burs - Pointed Tree

D1	L1	D2	L2	Singlecut
1/8	1/4	1/8	1-1/2	SG-41SC*
1/8	3/8	1/8	1-1/2	SG-43SC*
1/8	1/2	1/8	1-1/2	SG-44SC*
1/4	1/2	1/8	2	SG-51SC
1/4	5/8	1/4	2	SG-16SC*
1/4	5/8	1/4	6-3/4	SG-1L6SC
5/16	3/4	1/4	2-1/2	SG-2SC
3/8	3/4	1/4	2-1/2	SG-3SC
3/8	3/4	1/4	6-3/4	SG-3L6SC
1/2	3/4	1/4	2-1/2	SG-13SC
1/2	1	1/4	2-3/4	SG-5SC
1/2	1	1/4	6-3/4	SG-5L6SC
5/8	1	1/4	2-3/4	SG-6SC
3/4	1	1/4	2-3/4	SG-7SC
3/4	1-1/2	1/4	3-1/4	SG-15SC

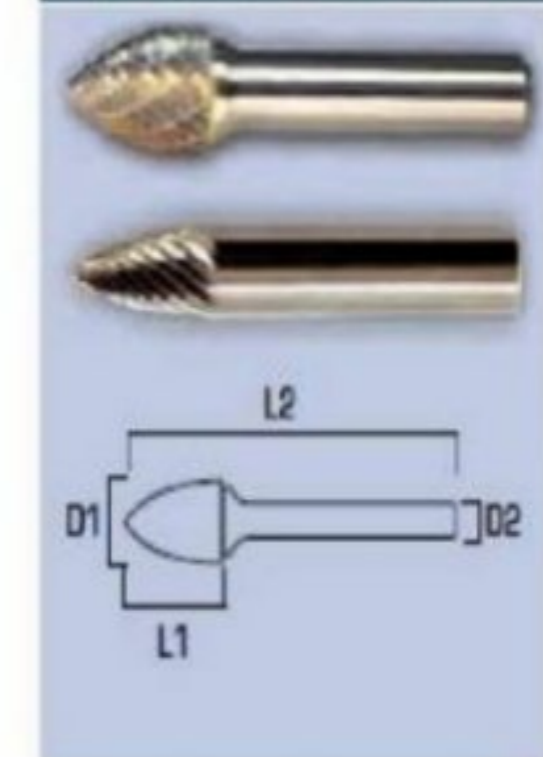

almacen\_ferrobrero@hotmail.com **¡envíanos tu cotización!**



# Herramientas de Corte



ref. 3125 3225

**1" Opción Agujeros Pesantes**  
**A.R.L.: Alto Rendimiento Intensivo**  
**Máquina Máquina con Entrada Corregida que empuja la viruta hacia el Fondo del Agujero**  
**Possible Use en Seco (Vs 50%)**  
**Se recomienda usar Aceite Corte IZAR**

1" Chisel Through Hole  
 H.P.C.: High Performance Cutting  
 Machine tool with Spiral Point that pushes chips to Hole Bottom  
 Dry Use possible (Vs 50%)  
 \*ZAR Cutting Oil Use recommended

1" Opción Troca desmontable  
 H.P.C.: Haut Rendement Intense  
 Machine Machine avec Entrée Corrigée qui pousse les copeaux vers le fond du trou  
 Possible utilisation en Sec (Vs 50%)  
 On suggère utiliser Huile de Coupe IZAR

Especificaciones Corte recomendadas				Recomendaciones Corting Conditions			
Vel. Rotación (RPM)	Vel. Avance (mm/min)	Vel. Rotación (RPM)	Vel. Avance (mm/min)	Vel. Rotación (RPM)	Vel. Avance (mm/min)	Vel. Rotación (RPM)	Vel. Avance (mm/min)
1000	100	1000	100	1000	100	1000	100
1500	150	1500	150	1500	150	1500	150
2000	200	2000	200	2000	200	2000	200
2500	250	2500	250	2500	250	2500	250
3000	300	3000	300	3000	300	3000	300
3500	350	3500	350	3500	350	3500	350
4000	400	4000	400	4000	400	4000	400
4500	450	4500	450	4500	450	4500	450
5000	500	5000	500	5000	500	5000	500
5500	550	5500	550	5500	550	5500	550
6000	600	6000	600	6000	600	6000	600
6500	650	6500	650	6500	650	6500	650
7000	700	7000	700	7000	700	7000	700
7500	750	7500	750	7500	750	7500	750
8000	800	8000	800	8000	800	8000	800
8500	850	8500	850	8500	850	8500	850
9000	900	9000	900	9000	900	9000	900
9500	950	9500	950	9500	950	9500	950
10000	1000	10000	1000	10000	1000	10000	1000

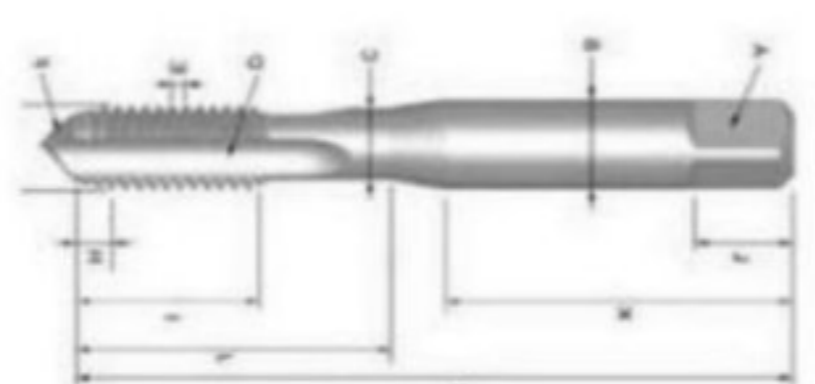

almacen\_ferrobrero@hotmail.com **¡envíanos tu cotización!**



## Machuelos Helicoidales

Corte a la Derecha ACERO ALTA VELOCIDAD - M2

### Tamaños Numéricos

Tamaño Macho	Hilos por Plg.	Limite H	Código	
			Semi Cónico	Recto
3	48	H2	5-762-030	5-762-031
3	56	H2	5-762-040	5-762-041
4	40	H2	5-762-050	5-762-051
5	40	H2	5-762-070	5-762-071
5	44	H2	5-762-080	5-762-081
6	32	H3	5-762-100	5-762-101
6	40	H2	5-762-110	5-762-111
8	32	H3	5-762-130	5-762-131
8	36	H3	5-762-140	5-762-141
10	24	H3	5-762-160	5-762-161
10	32	H3	5-762-170	5-762-171
12	24	H3	5-762-190	5-762-191
12	28	H3	5-762-200	5-762-201

### Tamaños Fraccionales

Tamaño Macho	Hilo por Plg.	Limite H	Código	
			Cónico	Recto
1/4	20	H3	5-760-050	5-760-051
1/4	28	H3	5-760-060	5-760-061
5/16	18	H3	5-760-080	5-760-081
5/16	24	H3	5-760-090	5-760-091
3/8	16	H3	5-760-110	5-760-111
3/8	24	H3	5-760-120	5-760-121
7/16	14	H3	5-760-140	5-760-141
7/16	20	H3	5-760-150	5-760-151
1/2	13	H3	5-760-170	5-760-171
1/2	20	H3	5-760-180	5-760-181
9/16	12	H3	5-760-190	5-760-191
9/16	18	H3	5-760-200	5-760-201
5/8	11	H3	5-760-210	5-760-211
5/8	18	H3	5-760-220	5-760-221
11/16	11	H3	5-760-230	5-760-231
11/16	16	H3	5-760-240	5-760-241
3/4	10	H3	5-760-250	5-760-251
3/4	16	H3	5-760-260	5-760-261
7/8	9	H4	5-760-270	5-760-271
7/8	14	H4	5-760-290	5-760-291
1	8	H4	5-760-300	5-760-301
1	14	H4	5-760-320	5-760-321



### NPT y NPTF

Tamaño Macho (Tubería)	Hilos por Pulgada	Número de Filos	Largo Total	Largo de Rosca
1/16	27	5	2-1/8	11/16
1/8	27	5	2-1/8	3/4
1/4	18	5	2-7/16	1-1/16
3/8	18	5	2-9/16	1-1/16
1/2	14	5	3-1/8	1-3/8
3/4	14	5	3-1/4	1-3/8
1	11-1/2	5	3-3/4	1-3/4
1-1/4	11-1/2	5	4	1-3/4
1-1/2	11-1/2	7	4-1/2	1-3/4
2	11-1/2	7	4-1/2	1-3/4



## Machuelo para Tubería (o Tubo)

ACERO ALTA VELOCIDAD - M2

Rosca Rectificada

Machuelos Cónicos para Tubería (o Tubo), NPT  
Machuelos Rectos para Tubería (o Tubo), NPS

Tamaño Macho (Tubería)	Hilos por Pulgada	Número de Filos	Largo Total	Largo de Rosca	Cónico	
					Código NPT	Código NPS
1/16	27	4	2-1/8	11/16	5-764-001	5-763-001
1/8	27	4	2-1/8	3/4	5-764-002	5-763-002
1/4	18	4	2-7/16	1-1/16	5-764-003	5-763-003
3/8	18	4	2-9/16	1-1/16	5-764-004	5-763-004
1/2	14	4	3-1/8	1-3/8	5-764-005	5-763-005
3/4	14	5	3-1/4	1-3/8	5-764-006	5-763-006
1	11-1/2	5	3-3/4	1-3/4	5-764-007	5-763-007
1-1/4	11-1/2	5	4	1-3/4	5-764-008	5-763-008
1-1/2	11-1/2	7	4-1/4	1-3/4	5-764-009	5-763-009
2	11-1/2	7	4-1/2	1-3/4	5-764-010	5-763-010
2-1/2	8	8	5-1/2	2-9/16	5-764-011	5-763-011
3	8	8	6	2-5/8	5-764-012	5-763-012
3-1/2	8	8	6-1/2	2-11/16	5-764-013	-
4	8	8	6-3/4	2-3/4	5-764-014	-



## Machuelos Métricos

"Gun" para Máquina

Semicónicos

Tamaño Macho (mm)	Paso (mm)	Código
1.6	0.35	5-776-001
1.8	0.35	5-776-002
2.0	0.40	5-776-003
2.2	0.45	5-776-004
2.5	0.45	5-776-005
3.0	0.50	5-776-006
3.5	0.60	5-776-007
4.0	0.70	5-776-008
4.0	0.50	5-776-0085
4.5	0.75	5-776-009
5.0	0.80	5-776-010
5.0	0.50	5-776-0105
6.0	1.00	5-776-011
6.0	0.75	5-776-0115
6.3	1.00	5-776-012
7.0	1.00	5-776-013
8.0	1.25	5-776-014
8.0	1.00	5-776-015
10.0	1.50	5-776-016
10.0	1.25	5-776-017
10.0	1.00	5-776-0175
12.0	1.75	5-776-018
12.0	1.50	5-776-0185
12.0	1.25	5-776-019
14.0	2.00	5-776-020
14.0	1.50	5-776-021
14.0	1.25	5-776-0215
16.0	2.00	5-776-022
16.0	1.50	5-776-023
18.0	2.50	5-776-024
20.0	2.50	5-776-025



almacen\_ferrobrero@hotmail.com envíanos tu cotización!





**GALGA MULTIPLE**



[almacen\\_ferrobrero@hotmail.com](mailto:almacen_ferrobrero@hotmail.com) **¡envíanos tu cotización!**



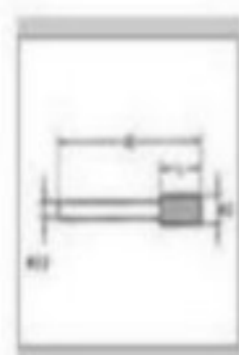
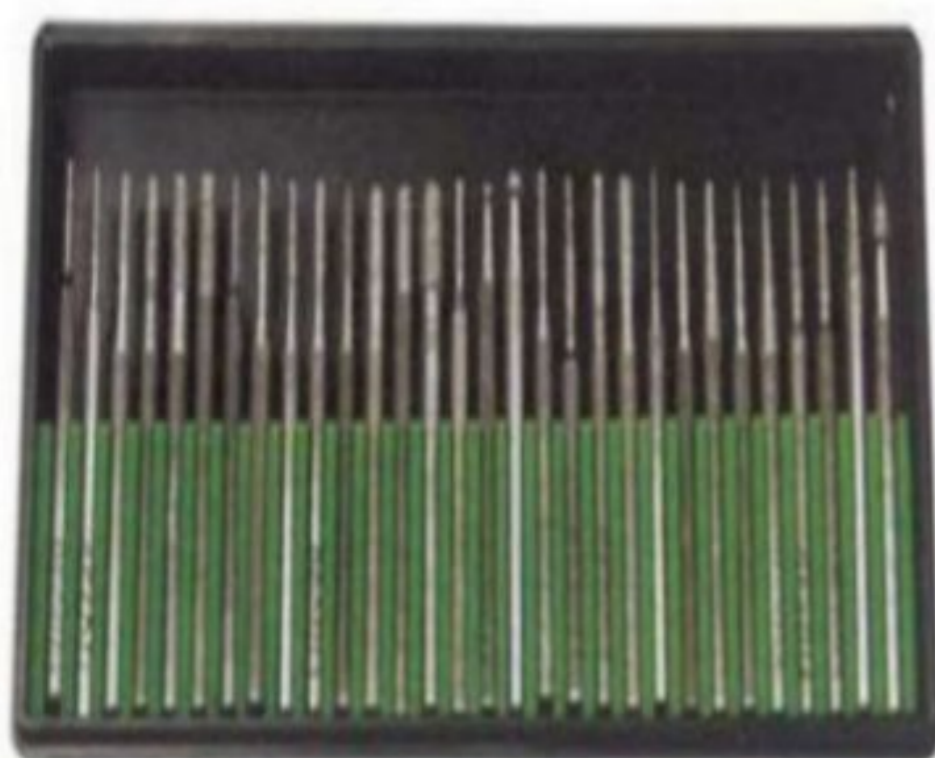

30F	Ø3	10
50F	Ø5	10
30S	Ø3	6

### FRESAS DIAMANTADAS

ORDER NO.	D	L
10A	Ø1	8
15A	Ø1.5	8
20A	Ø2	8
25A	Ø2.5	8
30A	Ø3	10
35A	Ø3.5	10
40A	Ø4	10
50A	Ø5	10
15C	Ø1.5	8
20C	Ø2	8
25C	Ø2.5	8
30C	Ø3	10
35C	Ø3.5	10

40C	Ø4	10
50C	Ø5	10
20B	Ø2	
30B	Ø3	
50B	Ø5	
20T	Ø2	10
30T	Ø3	10
30V	Ø3	10
15R	Ø1.5	10
20R	Ø2	12
30R	Ø3	14
20P	Ø2	12
30P	Ø3	15
20F	Ø2	10
30F	Ø3	10



almacen\_ferrobrero@hotmail.com ¡envíanos tu cotización!



## Machuelos Izquierdos

Corte a la Izquierda

Tamaño Macho	Hilos por Plg.	Límite H	Largo Total	Juego
1/4	20	H3	2-1/2	5-756-0029
1/4	28	H3	2-1/2	5-756-0045
5/16	18	H3	2-23/32	5-756-0067
5/16	24	H3	2-23/32	5-756-0083
3/8	16	H3	2-15/16	5-756-0102
3/8	24	H3	2-15/16	5-756-0124
7/16	14	H3	3-5/32	5-756-0143
7/16	20	H3	3-5/32	5-756-0189
1/2	13	H3	3-3/8	5-756-0191
1/2	20	H3	3-3/8	5-756-0206
9/16	12	H3	3-19/32	5-756-0225
9/16	18	H3	3-19/32	5-756-0241
9/16	24	H3	3-19/32	-
5/8	11	H3	3-13/16	5-756-0296
5/8	11	H5	3-13/16	-
5/8	18	H3	3-13/16	5-756-0296
3/4	10	H2	4-1/4	-
3/4	10	H3	4-1/4	5-756-0386
3/4	16	H3	4-1/4	5-756-0408
7/8	9	H3	4-11/16	5-756-0430
7/8	9	H4	4-11/16	-
7/8	12	H5	4-11/16	-
7/8	14	H3	4-11/16	5-756-0470
1	8	H3	5-1/8	5-756-0498
1	8	H4	5-1/8	-
1	12	H3	5-1/8	5-756-0536
1	14	H4	5-1/8	-
1-1/8	7	H3	5-7/16	-
1-1/8	8	H4	5-7/16	-
1-1/8	12	H3	5-7/16	-
1-1/8	12	H4	5-7/16	5-756-0702
1-1/4	7	H4	5-3/4	-
1-1/4	8	H4	5-3/4	-
1-1/4	12	H4	5-3/4	-
1-3/8	6	H4	6	-
1-3/8	8	H4	6	-
1-3/8	12	H4	6	-
1-1/2	6	H4	6-1/4	5-756-1027
1-1/2	8	H4	6-1/4	-
1-1/2	12	H3	6-1/4	-
1-1/2	12	H4	6-1/4	-
1-3/4	8	H4	7	-

ACERO ALTA VELOCIDAD - M2

Tamaño Macho	Hilos por Plg.	Semi Cónico Código
6	32	5-752-6000
8	32	5-752-6040
10	32	5-752-6060

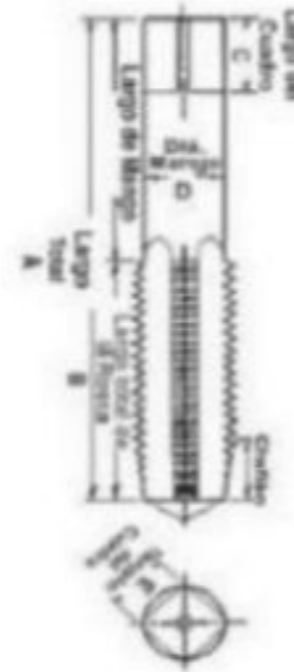

## Machuelos Helicoidales

Corte a la Derecha ACERO ALTA VELOCIDAD - M2

Tamaños Numéricos

Tamaño Macho	Hilos por Plg.	Límite H	Código	
			Semi Cónico	Recto
3	48	H2	5-762-030	5-762-031
3	56	H2	5-762-040	5-762-041
4	40	H2	5-762-050	5-762-051
5	40	H2	5-762-070	5-762-071
5	44	H2	5-762-080	5-762-081
6	32	H3	5-762-100	5-762-101
6	40	H2	5-762-110	5-762-111
8	32	H3	5-762-130	5-762-131
8	36	H3	5-762-140	5-762-141
10	24	H3	5-762-160	5-762-161
10	32	H3	5-762-170	5-762-171
12	24	H3	5-762-190	5-762-191
12	28	H3	5-762-200	5-762-201

Tamaños Fraccionales

Tamaño Macho	Hilo por Plg.	Límite H	Código	
			Cónico	Recto
1/4	20	H3	5-760-050	5-760-051
1/4	28	H3	5-760-060	5-760-061
5/16	18	H3	5-760-080	5-760-081
5/16	24	H3	5-760-090	5-760-091
3/8	16	H3	5-760-110	5-760-111
3/8	24	H3	5-760-120	5-760-121
7/16	14	H3	5-760-140	5-760-141
7/16	20	H3	5-760-150	5-760-151
1/2	13	H3	5-760-170	5-760-171
1/2	20	H3	5-760-180	5-760-181
9/16	12	H3	5-760-190	5-760-191
9/16	18	H3	5-760-200	5-760-201
5/8	11	H3	5-760-210	5-760-211
5/8	18	H3	5-760-220	5-760-221
11/16	11	H3	5-760-230	5-760-231
11/16	16	H3	5-760-240	5-760-241
3/4	10	H3	5-760-250	5-760-251
3/4	16	H3	5-760-260	5-760-261
7/8	9	H4	5-760-270	5-760-271
7/8	14	H4	5-760-290	5-760-291
1	8	H4	5-760-300	5-760-301
1	14	H4	5-760-320	5-760-321





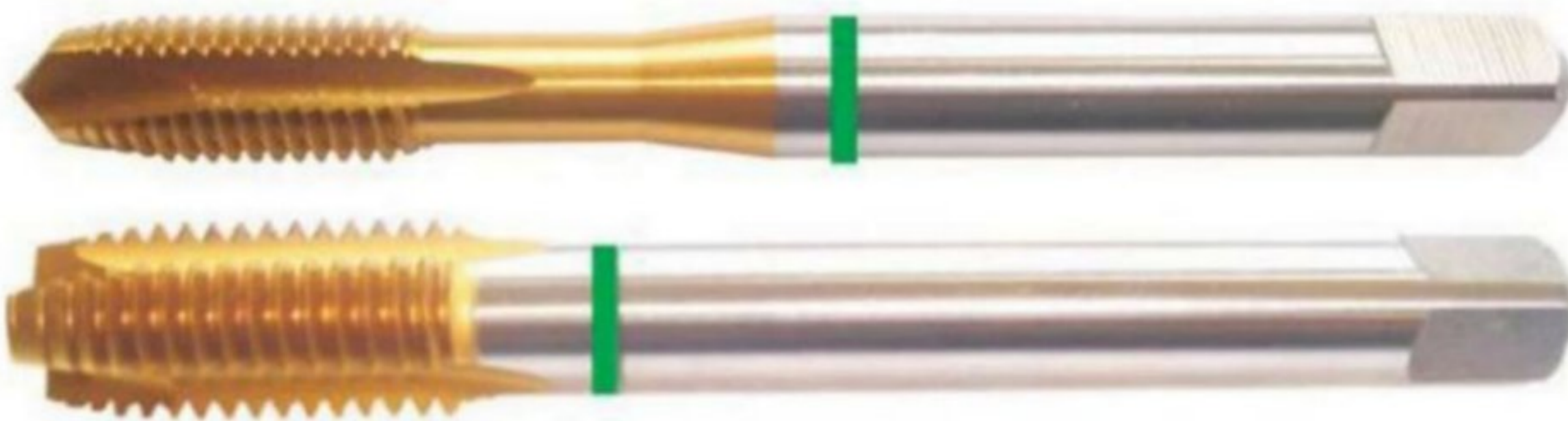

**MACHOS DIN 371 376 PARA MAQUINA**

almacen\_ferrobrero@hotmail.com **¡envíanos tu cotización!**



## Machuelos "Gun" para Máquina

Punta en Espiral  
Corte a la Derecha

ACERO ALTA VELOCIDAD - M2

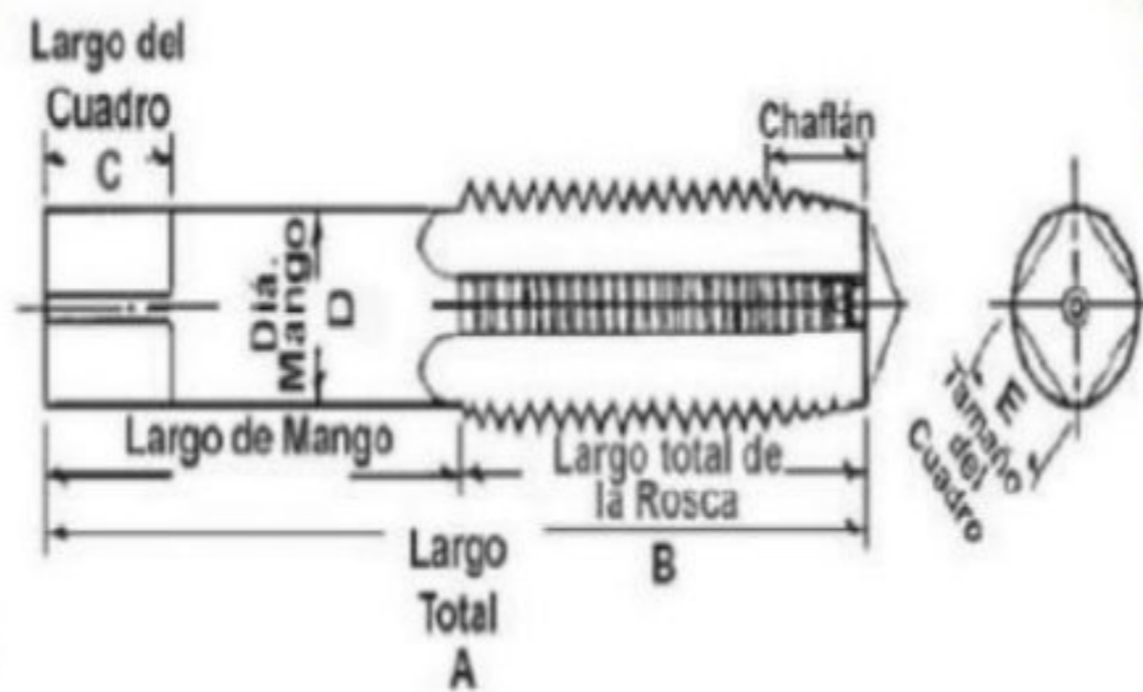

Tamaño Macho	Hilos por Plg.	Limite H	Largo Total	Código
0	80	H2	1-5/8	5-772-022
1	64	H2	1-11/16	5-772-032
	72	H2	1-11/16	5-772-043
2	56	H2	1-3/4	5-772-052
	64	H2	1-3/4	5-772-063
3	48	H2	1-3/16	5-772-077
	56	H2	1-3/16	5-772-088
4	40	H2	1-7/8	5-772-113
	48	H2	7 - 7/8	5-772-124
5	40	H2	1-15/16	5-772-138
	44	H2	1-15/16	5-772-149
6	32	H2	2	5-772-163
	32	H3	2	5-772-165
	32	H13	2	5-772-550
	40	H2	2	5-772-174
8	40	H3	2	5-772-176
	32	H2	2-1/8	5-772-188
	32	H3	2-1/8	5-772-190
	36	H2	2-1/8	5-772-199
10	36	H3	2-1/8	5-772-201
	24	H2	2-3/8	5-772-210
	24	H3	2-3/8	5-772-215
	24	H13	2-3/8	5-772-590
12	32	H3	2-3/8	5-772-226
	32	H13	2-3/8	5-772-610
	24	H3	2-3/8	5-772-240
	28	H3	2-3/8	5-772-251

## Rosca Rectificada / Tamaños Fraccionales Dimensiones

Diámetro del Macho	Hilos por Pulgada		Largo Total A	Largo de la Rosca B	No. de Filos	Largo del Cuadro C	Diámetro del Mango D	Tamaño del Cuadro E
	NC	NF						
1/4	20	28	2-1/2	1	2	5/16	.255	.191
5/16	18	24	2-23/32	1-1/8	2	3/8	.318	.238
3/8	16	24	2-15/16	1-1/4	3	7/16	.381	.286
7/16	14	20	3-5/32	1-7/16	3	13/32	.323	.242
1/2	13	20	3-3/8	1-21/32	3	7/16	.367	.275
9/16	12	18	3-19/32	1-21/32	3	1/2	.429	.322
5/8	11	18	3-13/16	1-13/16	3	9/16	.480	.360
3/4	10	16	4-1/4	2	3	11/16	.590	.442
7/8	9	14	4-11/16	2-7/32	3	3/4	.697	.523
1	8	12	5-1/8	2-1/2	3	13/16	.800	.600







Corte y Medición



Herramientas de Corte  
 Instrumentos de Precisión

- Rimas
- Brocas
- Brocaladores
- Avellanadores
- Fresas Verticales
- Cortadores Anulares
- Fresas Circulares
- Fresas para Engranajes
- Sierras Circulares
- Machuelos
- Dados



**BROCA ESCALONADA**

almacen\_ferrobrero@hotmail.com [¡envíanos tu cotización!](#)





almacen\_ferrobrero@hotmail.com **¡envíanos tu cotización!**



Juego de 29 piezas  
 5-160-700, 5-160-700G,  
 5-158-700G  
 Tamaños 1/16" a 1/2" X 64avos.  
 Incluye estuche metálico



Juego de 25 piezas  
 5-161-700  
 Tamaño 1.0 hasta 13.0 mm



### Brocas Métricas de Mango Reducido

Mangos Reducidos a Diámetro 1/2"

12.5 MM	.4921	5-167-125	25.5 MM	1.0039	5-167-255
13.0 MM	.5118	5-167-130	26.0 MM	1.0236	5-167-260
13.5 MM	.5315	5-167-135	26.5 MM	1.0433	5-167-265
14.0 MM	.5512	5-167-140	27.0 MM	1.0630	5-167-270
14.5 MM	.5709	5-167-145	27.5 MM	1.0837	5-167-275
15.0 MM	.5906	5-167-150	28.0 MM	1.1024	5-167-280
15.5 MM	.6102	5-167-155	28.5 MM	1.1220	5-167-285
16.0 MM	.6299	5-167-160	29.0 MM	1.1417	5-167-290
16.5 MM	.6496	5-167-165	29.5 MM	1.1614	5-167-295
17.0 MM	.6693	5-167-170	30.0 MM	1.1811	5-167-300
17.5 MM	.6890	5-167-175	30.5 MM	1.2008	5-167-305
18.0 MM	.7087	5-167-180	31.0 MM	1.2205	5-167-310
18.5 MM	.7283	5-167-185	31.5 MM	1.2402	5-167-315
19.0 MM	.7480	5-167-190	32.0 MM	1.2598	5-167-320
19.5 MM	.7677	5-167-195	32.5 MM	1.2795	5-167-325
20.0 MM	.7874	5-167-200	33.0 MM	1.2992	5-167-330
20.5 MM	.8071	5-167-205	33.5 MM	1.3189	5-167-335
21.0 MM	.8268	5-167-210	34.0 MM	1.3386	5-167-340
21.5 MM	.8465	5-167-215	34.5 MM	1.3583	5-167-345
22.0 MM	.8661	5-167-220	35.0 MM	1.3780	5-167-350
22.5 MM	.8858	5-167-225	35.5 MM	1.3976	5-167-355
23.0 MM	.9055	5-167-230	36.0 MM	1.4173	5-167-360
23.5 MM	.9252	5-167-235	36.5 MM	1.4370	5-167-365
24.0 MM	.9449	5-167-240	37.0 MM	1.4567	5-167-370
24.5 MM	.9646	5-167-245	37.5 MM	1.4764	5-167-375
25.0 MM	.9843	5-167-250	38.0 MM	1.4961	5-167-380

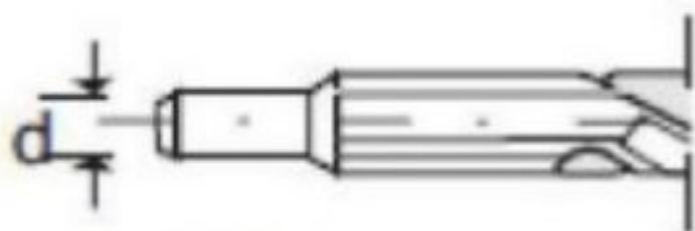

d = 1/2"



almacen\_ferrobrero@hotmail.com [envíanos tu cotización!](#)



















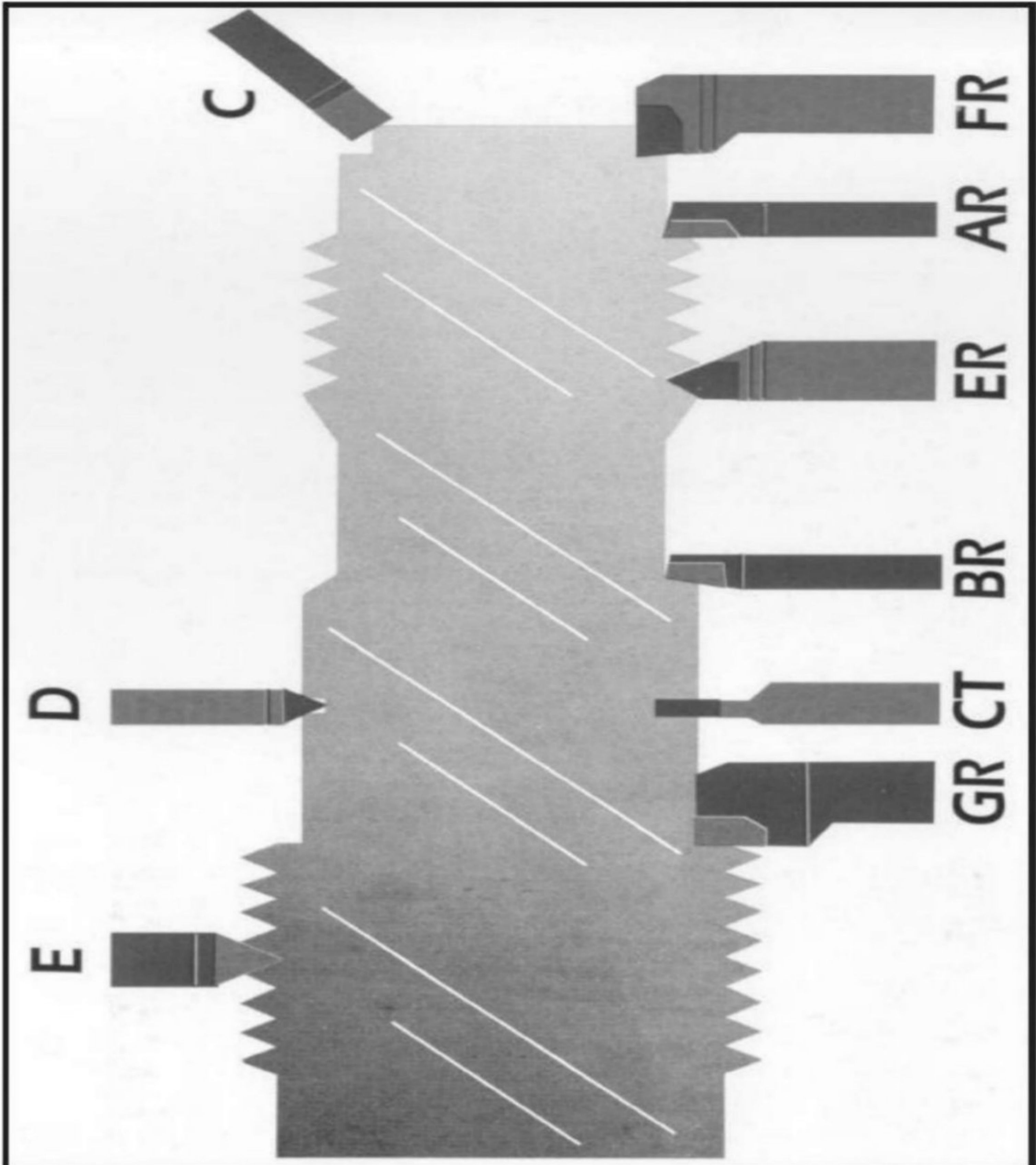



## Buriles con Punta de Pastilla de Carburo

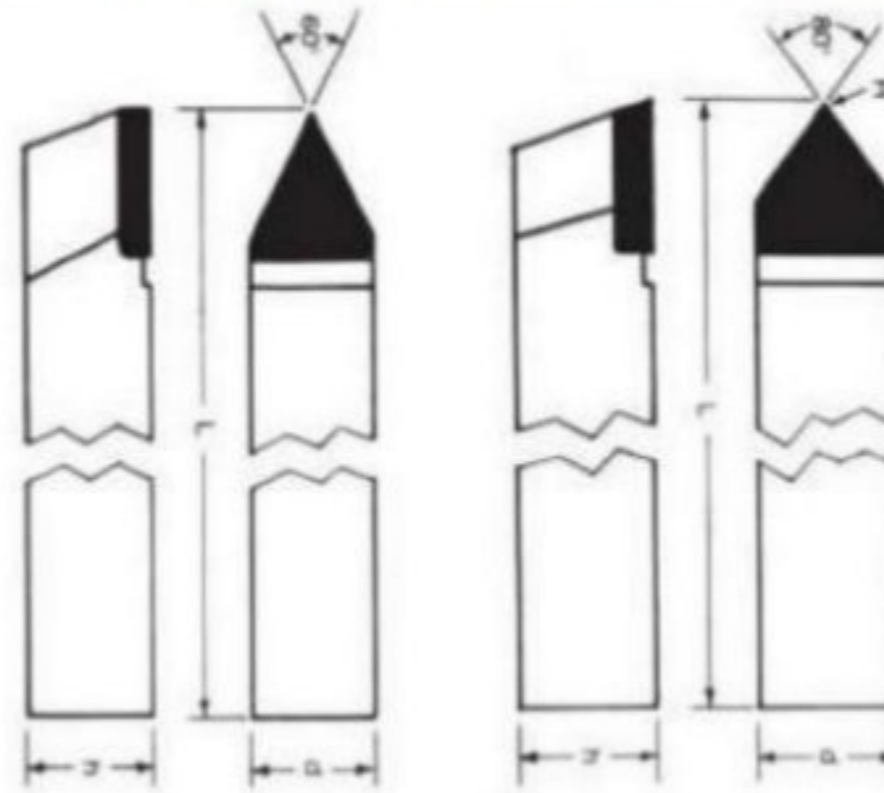
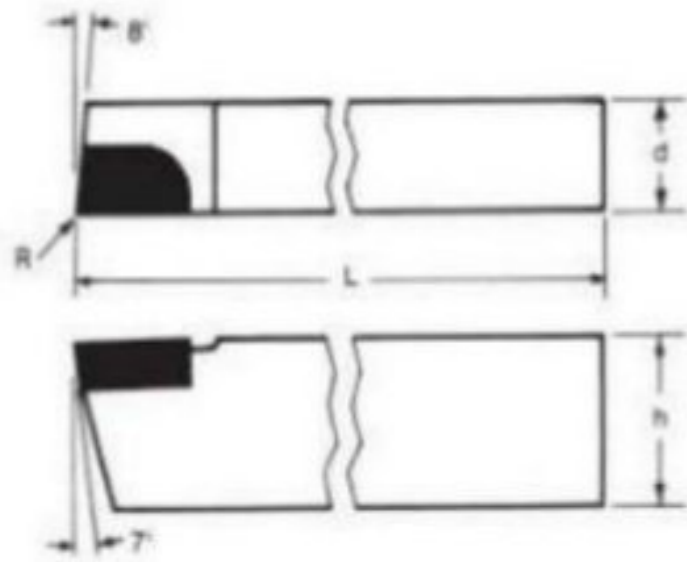

Corte a la Derecha	Corte a la Izquierda	d	L	Radio	No.
Torneado Estilo A					
AR4	AL4	1/4	2	1/64	2040
AR5	AL5	5/16	2-1/4	1/64	2070
AR6	AL6	3/8	2-1/2	1/64	2070
AR7	AL7	7/16	3	1/32	2070
AR8	AL8	1/2	3-1/2	1/32	2170
AR10	AL10	5/8	4	1/32	2230
AR12	AL12	3/4	4-1/2	1/32	2310
AR16	AL16	1	7	-	-

E4	1/4	2
E5	5/16	2-1/4
E6	3/8	2-1/2
E7	7/16	3
E8	1/2	3-1/2
E10	5/8	4
E12	3/4	4-1/2
E16	1	7



## Buril Rectificado

ACERO ALTA VELOCIDAD M2 (W 7%, Mo 5%)



### Cuadrado

Dimensiones	AAV Código	Código Acero Cobalto
1/8 x 2-1/2	5-092-002	5-095-002
3/16 x 2-1/2	5-092-007	5-095-007
1/4 x 2-1/2	5-092-012	5-095-012
5/16 x 2-1/2	5-092-017	5-095-017
5/16 x 3	5-092-018	5-095-018
5/16 x 4	5-092-020	-
3/8 x 3	5-092-022	5-095-022
3/8 x 4	5-092-024	-
7/16 x 3-1/2	5-092-028	5-095-028
1/2 x 4	5-092-032	5-095-032
5/8 x 4-1/2	5-092-042	5-095-042
3/4 x 5	5-092-052	5-095-052

### Cuadrado-Largo

Dimensiones	AAV Código	Código Acero Cobalto
7/8 x 6	5-092-063	5-095-063
1 x 7	5-092-073	5-095-073
1-1/4 x 7	5-092-077	5-095-077
1-1/4 x 4	5-092-108	5-095-108
1/4 x 6	5-092-110	5-095-110
1/4 x 8	5-092-112	5-095-112
5/16 x 6	5-092-115	5-095-115
5/16 x 8	5-092-117	5-095-117
3/8 x 6	5-092-120	5-095-120
3/8 x 8	5-092-122	5-095-122
1/2 x 6	5-092-130	5-095-130
1/2 x 8	5-092-132	5-095-132
5/8 x 8	5-092-142	5-095-142

### Redondo

Dimensiones	Código AAV
1/8 x 2-3/4	5-091-002
3/16 x 3-1/2	5-091-008
1/4 x 4	5-091-013
5/16 x 4-1/2	5-091-018
3/8 x 5	5-091-023
7/16 x 5-1/2	5-091-028
1/2 x 6	5-091-033
9/16 x 6	5-091-038
5/8 x 6	5-091-043
3/4 x 6	5-091-053
1/8 x 4	5-091-116
1/4 x 8	5-091-126
5/16 x 8	5-091-136

### Rectangular

Dimensiones	Código AAV	Código Acero Cobalto
1/4 x 3/8 x 3	5-093-008	-
1/4 x 3/8 x 4	-	5-094-010
1/4 x 1/2 x 4	5-093-012	5-094-012
1/4 x 1/2 x 6	-	5-094-014
1/4 x 3/4 x 5	5-093-016	-
1/4 x 1 x 6	5-093-020	5-094-020
3/8 x 1/2 x 4	5-093-032	5-094-032
3/8 x 5/8 x 4-1/2	5-093-036	-
3/8 x 3/4 x 5	5-093-040	5-094-040
1/2 x 3/4 x 5	5-093-048	5-094-048
1/2 x 1 x 7	5-093-052	5-094-052
1/2 x 1-1/4 x 7	5-093-056	-
5/8 x 3/4 x 5	5-093-064	-
5/8 x 7/8 x 6	5-093-068	-
5/8 x 1 x 7	5-093-072	-
5/8 x 1-1/4 x 7	5-093-076	-
3/4 x 1 x 6	5-093-082	-
3/4 x 1 x 7	5-093-084	5-094-084
3/4 x 1-1/4 x 6	5-093-086	-
3/4 x 1-1/4 x 7	5-093-088	-





# LIMAS PARA JOYERIA DIAMANTADAS

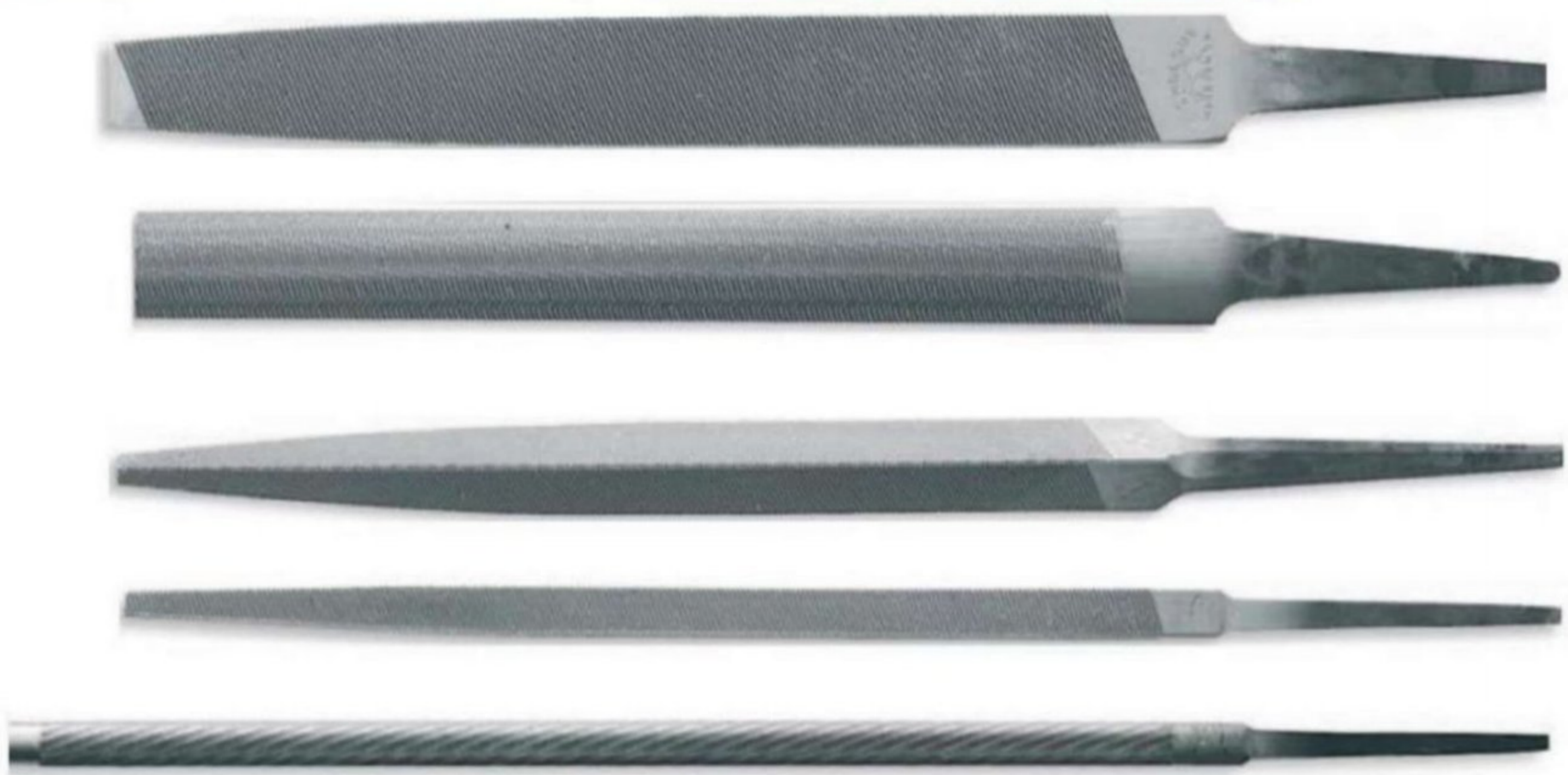

almacen\_ferrobrero@hotmail.com [envíanos tu cotización!](#)









# FRESAS ESCARIADORAS TUNGSTENO

## BROCAS EN TUNGSTENO

### Standard Solid Carbide Drills



Resharpen drills at first sign of dulling or rounding.

### Drill Recommendations

Material Group	Speed (RPM)	Feed Rate (IPR)				
		1/16"	1/8"	1/4"	1/2"	3/4"
Aluminum / Aluminum Alloys	300-600	.0008	.002	.007	.012	.018
Aluminum Alloyed Si > 10%	180-400	.0008	.002	.006	.010	.012
Soft Cast Irons	300-300	.001	.002	.006	.010	.012
Medium Cast Irons	125-225	.001	.002	.006	.008	.010
Malleable Cast Irons	80-200	.0008	.002	.004	.007	.010
Brass	300-300	.0007	.002	.002	.004	.006
Bronze	180-250	.0007	.002	.002	.004	.006
Copper / Copper Alloys	180-200	.001	.002	.006	.010	.012
Magnesium	300-600	.001	.002	.007	.012	.018
Nickel Alloys	75-200	.001	.002	.006	.008	.012
Free Machining Stainless Steels	100-150	.001	.002	.006	.008	.012
Work Hardening Stainless Steels	80-100	.0008	.002	.004	.006	.010
Low Carbon Steels	180-200	.001	.002	.004	.007	.012
Medium Carbon Steels	100-200	.001	.002	.002	.006	.010
High Tensile (35-42 Rc) Steels	75-150	.001	.002	.002	.004	.006
High Tensile (40-45 Rc) Steels	80-100	.0007	.001	.002	.003	.004
High Tensile (45 Rc+) Steels	25-75	.0008	.0007	.001	.002	.003
Tool Steels	40-100	.001	.0015	.002	.006	.008
Soft Titanium	80-125	.001	.002	.004	.006	.010
Titanium Alloy Hard Titanium	40-100	.0007	.001	.002	.006	.008



## Rimas de Mano

### Filo Espiral y Recto

### Mango Recto

### Corte a la Derecha

#### ACERO ALTA VELOCIDAD



Para uso en todas las aplicaciones donde se desea una operación manual de extremada precisión.

Tamaño Diámetro	Largo Total	Largo Filo	Recto Código	Espiral Código
1/8	3	1-1/2	5-005-005	5-010-005
9/64	3-1/4	1-5/8	5-005-008	—
5/32	3-1/4	1-5/8	5-005-010	5-010-010
11/64	3-1/2	1-3/4	5-005-012	—
3/16	3-1/2	1-3/4	5-005-015	5-010-015
7/32	3-3/4	1-7/8	5-005-020	5-010-020
1/4	4	2	5-005-025	5-010-025
9/32	4-1/4	2-1/8	5-005-030	5-010-030
5/16	4-1/2	2-1/4	5-005-035	5-010-035
11/32	4-3/4	2-3/8	5-005-040	5-010-040
25/64	4-3/4	2-1/2	5-005-042	—
3/8	5	2-1/2	5-005-045	5-010-045
13/32	5-1/4	2-5/8	5-005-050	5-010-050
7/16	5-1/2	2-3/4	5-005-055	5-010-055
15/32	5-3/4	2-7/8	5-005-060	5-010-060
31/64	6	3	5-005-062	5-010-062
1/2	6	3	5-005-065	5-010-065
17/32	6-1/4	3-1/8	5-005-070	5-010-070
9/16	6-1/2	3-1/4	5-005-075	5-010-075
19/32	6-3/4	3-3/8	5-005-080	5-010-080
5/8	7	3-1/2	5-005-085	5-010-085
21/32	7-3/8	3-11/16	5-005-090	5-010-090
11/16	7-3/4	3-7/8	5-005-095	5-010-095
23/32	8-1/8	4-1/16	5-005-100	5-010-100
3/4	8-3/8	4-3/16	5-005-105	5-010-105
25/32	8-3/4	4-3/8	5-005-110	5-010-110
13/16	9-1/8	4-9/16	5-005-115	5-010-115
27/32	9-3/8	4-11/16	5-005-120	5-010-120
7/8	9-3/4	4-7/8	5-005-125	5-010-125
29/32	10	5	5-005-130	5-010-130
15/16	10-1/4	5-1/8	5-005-135	5-010-135
31/32	10-5/8	5-5/16	5-005-140	5-010-140
1	10-7/8	5-7/16	5-005-145	5-010-145
1-1/16	11-1/4	5-5/8	5-005-150	5-010-150
1-1/8	11-5/8	5-13/16	5-005-155	5-010-155
1-3/16	12	6	5-005-160	5-010-160
1-1/4	12-1/4	6-1/8	5-005-165	5-010-165
1-5/16	12-1/2	6-1/4	5-005-170	5-010-170
1-3/8	12-5/8	6-5/16	5-005-175	5-010-175
1-7/16	12-7/8	6-7/16	5-005-180	5-010-180
1-1/2	13	6-1/2	5-005-185	5-010-185

Tamaño Diámetro MM	Largo Filo	Largo Total	Filo Largo Código DIN 206/A	Filo Espiral Código DIN 206/B
3.0	31	62	5-006-005	5-011-005
3.2	33	66	5-006-010	5-011-010
3.5	35	71	5-006-015	5-011-015
4.0	38	76	5-006-020	5-011-020
4.5	41	81	5-006-025	5-011-025
5.0	44	87	5-006-030	5-011-030
5.5	47	93	5-006-035	5-011-035
6.0	47	93	5-006-040	5-011-040
6.5	50	100	5-006-042	—
7.0	54	107	5-006-045	5-011-045
7.5	54	107	5-006-047	—
8.0	58	115	5-006-050	5-011-050
8.5	58	115	5-006-052	—
9.0	62	124	5-006-055	5-011-055
9.5	62	124	5-006-057	—
10.0	66	133	5-006-060	5-011-060
10.5	66	133	5-006-062	—
11.0	71	142	5-006-065	5-011-065
11.5	71	142	5-006-067	—
12.0	76	152	5-006-070	5-011-070
12.5	76	152	5-006-072	—
13.0	76	152	5-006-075	5-011-075
13.5	81	163	5-006-077	—
14.0	81	163	5-006-080	5-011-080
14.5	81	163	5-006-082	—
15.0	81	163	5-006-085	5-011-085
15.5	87	175	5-006-087	—
16.0	87	175	5-006-090	5-011-090
16.5	87	175	5-006-092	—
17.0	87	175	5-006-095	5-011-095
17.5	93	188	5-006-097	—
18.0	93	188	5-006-100	5-011-100
18.5	93	188	5-006-102	—
19.0	93	188	5-006-105	5-011-105
19.5	100	201	5-006-107	—
20.0	100	201	5-006-110	5-011-110

almacen\_ferrobrero@hotmail.com [envíanos tu cotización!](#)







## Dados Redondos Ajustables para Datos Redondos Ajustables

Tubo Cónico NPT

Tubo Recto NPS

Tamaño	Hilos por Plg.	Código
1" Diámetro Exterior		
1/16	27	5-816-005
1/8	27	5-816-010
1-1/2" Diámetro Exterior		
1/8	27	5-816-015
1/4	18	5-816-020
3/8	18	5-816-025
2" Diámetro Exterior		
1/4	18	5-816-030
3/8	18	5-816-035
1/2	14	5-816-040
3/4	14	5-816-045
2-1/2" Diámetro Exterior		
1"	11-1/2	5-816-050
3" O.D.		
1-1/4	11-1/2	5-816-055
1-1/2	11-1/2	5-816-060

Tamaño	Hilos por Plg.	Código
1" Diámetro Exterior		
1/16	27	5-815-005
1/8	27	5-815-010
1-1/2" Diámetro Exterior		
1/8	27	5-815-015
1/4	18	5-815-020
3/8	18	5-815-025
2" Diámetro Exterior		
1/4	18	5-815-030
3/8	18	5-815-035
1/2	14	5-815-040
3/4	14	5-815-045
2-1/2" Diámetro Exterior		
1"	11-1/2	5-815-050
3" Diámetro Exterior		
1-1/4	11-1/2	5-815-055

Rosca Ordinaria NC		
Tamaño Nominal	Hilos por Plg.	Código
13/16" Diámetro Exterior		
#0	-	-
#1	64	5-800-000
#2	56	5-800-001
#3	48	5-800-002
#4	40	5-800-003
#5	40	5-800-004
#6	32	5-800-005
#8	32	5-800-010
#10	24	5-800-015
#12	24	5-800-020
1/4	20	5-800-025
5/16	18	5-800-030
1" Diámetro Exterior		
#4	40	5-800-032
#5	40	5-800-034
#6	32	5-800-035
#8	32	5-800-040
#10	24	5-800-045
#12	24	5-800-050
1/4	20	5-800-055
5/16	18	5-800-060
3/8	16	5-800-065
7/16	14	5-800-070
1/2	13	5-800-075
1-1/2" Diámetro Exterior		
1/4	20	5-800-080
5/16	18	5-800-085
3/8	16	5-800-090
7/16	14	5-800-095
1/2	13	5-800-100
9/16	12	5-800-105
5/8	11	5-800-110
3/4	10	5-800-115

Rosca Fina NF		
Tamaño Nominal	Hilos por Plg.	Código
13/16" Diámetro Exterior		
#0	80	5-805-000
#1	72	5-805-005
#2	64	5-805-001
#3	56	5-805-002
#4	48	5-805-003
#5	44	5-805-004
#6	40	5-805-005
#8	36	5-805-010
#10	32	5-805-015
#12	28	5-805-020
1/4	28	5-805-025
5/16	24	5-805-030
1" Diámetro Exterior		
#4	48	5-805-034
#6	40	5-805-035
#8	36	5-805-040
#10	32	5-805-045
#12	28	5-805-050
1/4	28	5-805-055
5/16	24	5-805-060
3/8	24	5-805-065
7/16	20	5-805-070
1/2	20	5-805-075
1-1/2" Diámetro Exterior		
1/4	28	5-805-080
5/16	24	5-805-085
3/8	24	5-805-090
7/16	20	5-805-095
1/2	20	5-805-100
9/16	18	5-805-105
5/8	18	5-805-110
3/4	16	5-805-115



almacen\_ferrobrero@hotmail.com ¡envíanos tu cotización!



Tamaños Pulgada	Código 1" Profund.	Código 2" Profund.	Código 3" Profund.	Diámetro Interior	No. de Filos
7/16	5-530-110	5-530-210	-	0.256	4
1/2	5-530-111	5-530-211	-	0.264	4
9/16	5-530-113	5-530-213	-	0.284	4
5/8	5-530-118	5-530-218	-	0.291	4
11/16	5-530-119	5-530-219	-	0.311	4
3/4	5-530-121	5-530-221	-	0.370	5
13/16	5-530-124	5-530-224	5-530-324	0.440	6
7/8	5-530-127	5-530-227	5-530-327	0.488	6
15/16	5-530-130	5-530-230	5-530-330	0.559	6
1	5-530-133	5-530-233	5-530-333	0.606	6
1-1/16	5-530-136	5-530-236	5-530-336	0.669	6
1-1/8	5-530-139	5-530-239	5-530-339	0.709	8
1-3/16	5-530-142	5-530-242	5-530-342	0.772	8
1-1/4	5-530-145	5-530-245	5-530-345	0.835	8
1-5/16	5-530-148	5-530-248	5-530-348	0.894	8
1-3/8	5-530-151	5-530-251	5-530-351	0.957	8
1-7/16	5-530-154	5-530-254	5-530-354	1.020	8
1-1/2	5-530-157	5-530-257	5-530-357	1.083	9
1-9/16	5-530-160	5-530-260	5-530-360	1.146	10
1-5/8	5-530-163	5-530-263	5-530-363	1.209	10
1-11/16	5-530-168	5-530-268	5-530-368	1.272	10
1-3/4	5-530-169	5-530-269	5-530-369	1.335	12
1-13/16	5-530-172	5-530-272	5-530-372	1.386	12
1-7/8	5-530-175	5-530-275	5-530-375	1.457	12
1-15/16	5-530-178	5-530-278	5-530-378	1.520	12
2	5-530-181	5-530-281	5-530-381	1.583	12
2-1/16	5-530-183	5-530-283	5-530-383	1.630	14



### Fresas Angulares Sencillas

Corte a la Derecha y a la Izquierda en Ángulos de 45° y 60°



Diá.	Ancho de Cara	Tamaño del Hueco	No. de Dientes	Corte a la Derecha 45°	Corte a la Izquierda 45°	Corte a la Derecha 60°	Corte a la Izquierda 60°
2-1/2	1/2	7/8	18	5-712-005	5-715-005	5-712-010	5-715-010
2-3/4	1/2	1	18	5-712-015	5-715-015	5-712-020	5-715-020
3	1/2	1	22	5-712-025	5-715-025	5-712-030	5-715-030
3	1/2	1-1/4	22	5-712-025	5-715-025	5-712-030	5-715-030
3	5/8	1	22	5-712-035	5-715-035	5-712-040	5-715-040
3	5/8	1-1/4	22	5-712-045	5-715-045	5-712-050	5-715-050
3	3/4	1	22	5-712-055	5-715-055	5-712-060	5-715-060
3	3/4	1-1/4	22	-	-	5-712-070	5-715-070
4	1/2	1	26	5-712-075	5-715-075	5-712-080	5-715-080
4	1/2	1-1/4	26	5-712-085	5-715-085	5-712-090	5-715-090
4	3/4	1	26	5-712-095	5-715-095	5-712-100	5-715-100
4	3/4	1-1/4	26	5-712-105	5-715-105	5-712-110	5-715-110
4	1	1-1/4	26	5-712-115	5-715-115	5-712-120	5-715-120
5	3/4	1-1/4	28	5-712-125	5-715-125	5-712-130	5-715-130
5	1	1-1/4	28	5-712-135	5-715-135	5-712-140	5-715-140
6	3/4	1-1/4	30	5-712-145	5-715-145	5-712-150	5-715-150
6	1	1-1/4	30	5-712-155	5-715-155	5-712-160	5-715-160



### Fresa Angular Doble

Ángulos de 45°, 60°, 90° AFJh

Diá.	Ancho de Cara	Tamaño del Hueco	No. de Dientes	45°	60°	90°
2-3/4	1/2	1	18	5-718-005	5-718-010	5-718-015
3	5/8	1	22	5-718-020	5-718-025	5-718-030
3	3/4	1	22	-	5-718-035	5-718-040
4	1/2	1-1/4	26	5-718-045	5-718-050	5-718-055
4	3/4	1	26	5-718-060	5-718-065	5-718-070
4	3/4	1-1/4	26	5-718-075	5-718-080	5-718-085
4	1	1-1/4	26	-	5-718-090	5-718-095
5	3/4	1-1/4	28	5-718-100	5-718-105	5-718-110
5	1	1-1/4	28	5-718-115	5-718-120	5-718-125
6	3/4	1-1/4	30	5-718-130	5-718-135	5-718-140
6	1	1-1/4	30	5-718-145	5-718-150	5-718-155
6	1-1/2	1-1/4	30	5-718-160	5-718-165	5-718-170



**H&C**  
TOOLS AND CUTTING  
INTERNATIONAL SAS

### Fresas (Cortadores) Anulares

ACERO ALTA VELOCIDAD

- Elimina las múltiples pasadas de taladro
- Bajo costo por hueco
- Mejor acabado
- Mayor precisión, huecos más limpios
- Larga vida útil (puede afilarse de nuevo)
- Mango 3/4" diámetro y doble chafán para ambas fresas métricas y en pulgadas
- Las fresas son intercambiables con otros sistemas estándares para perforar agujeros

### Volvedor Ajustable para Machuelo Rima

Tamaño	Capacidad Macho	Rango Macho Tubo	Largo Total	Código
0	0-1/4"	-	6"	4-410-000
4	1/8-3/8"	-	7"	4-410-004
5	3/16-1/2"	1/8-1/4"	11-1/2"	4-410-005
6	1/4-3/4"	1/8-3/8"	15-3/8"	4-410-006

### Maneral Volvedor de Dados para Trabajo Pesado

Diámetro Dado Pulgada	Largo Total Pulgada	Código
13/16	6-1/4	4-400-005
1	9	4-400-010
1-1/2	12	4-400-015
2	19-1/2	4-400-020
2-1/2	20	4-400-025
3	22	4-400-030



almacen\_ferrobrero@hotmail.com envíanos tu cotización!





## RIMA EXPANSION

- REF. A5 de 8,0 - 9,0 mm
- REF. A4 de 9,0 - 10,0 mm
- REF. A3 de 10,0 - 11,0 mm
- REF. A2 de 11,0 - 12,0 mm
- REF. C de 12,0 - 13,5 mm
- REF. D de 13,5 - 15,5 mm
- REF. E de 15,5 - 18,0 mm
- REF. F de 18,0 - 21,0 mm
- REF. G de 21,0 - 24,0 mm
- REF. H de 24,0 - 27,5 mm
- REF. I de 27,5 - 31,5 mm
- REF. K de 31,5 - 37,0 mm
- REF. L de 37,0 - 45,0 mm
- REF. M de 45,0 - 55,0 mm
- REF. N de 56,0 - 67,0 mm
- REF. O de 67,0 - 78,0 mm
- REF. A2/I de 11,0 - 31,5 mm
- REF. A5/I de 8,0 - 31,5 mm
- REF. A5/M de 8,0 - 55,0 mm







# H&C

TOOLS AND CUTTING  
INTERNATIONAL SAS







PUNTA MONTADA

DISCOS P/PULIDORA



PIEDRAS ABRASIVAS



LIJA

**H&C**  
**TOOLS AND CUTTING**  
**INTERNATIONAL SAS**



LLAVE P/TUBO BESTLY  
 6",8",10",12"



LLAVE MIXTA



LLAVE EXPANSION  
 6",8",10",12"



ABECEDARIO DE GOLPE DERECHO 1.5 MM A 15MM

ABECEDARIO DE GOLPE IZQUIERDO 1.5 MM A 10MM

NUMERADOR DE GOLPE DERECHO T/PESADO 2.0 MM A 15.0 MM

NUMERADOR DE GOLPE IZQ C/EXTRAPESADO 1.5 MM A 8.0 MM



almacen\_ferrobrero@hotmail.com **envíanos tu cotización!**



### JUEGO DE BOQUILLAS P/TALADRO FRESADOR



- ER-8
- ER-11
- ER-11
- ER-16
- ER-16
- ER-20
- ER-20
- ER-25
- ER-25
- ER-25
- ER-25
- ER-25
- ER-32
- ER-32
- ER-40
- ER-40
- ER-40
- ER-50



almacen\_ferrobrero@hotmail.com **¡envíanos tu cotización!**



## REPARADORES DE ROSCAS

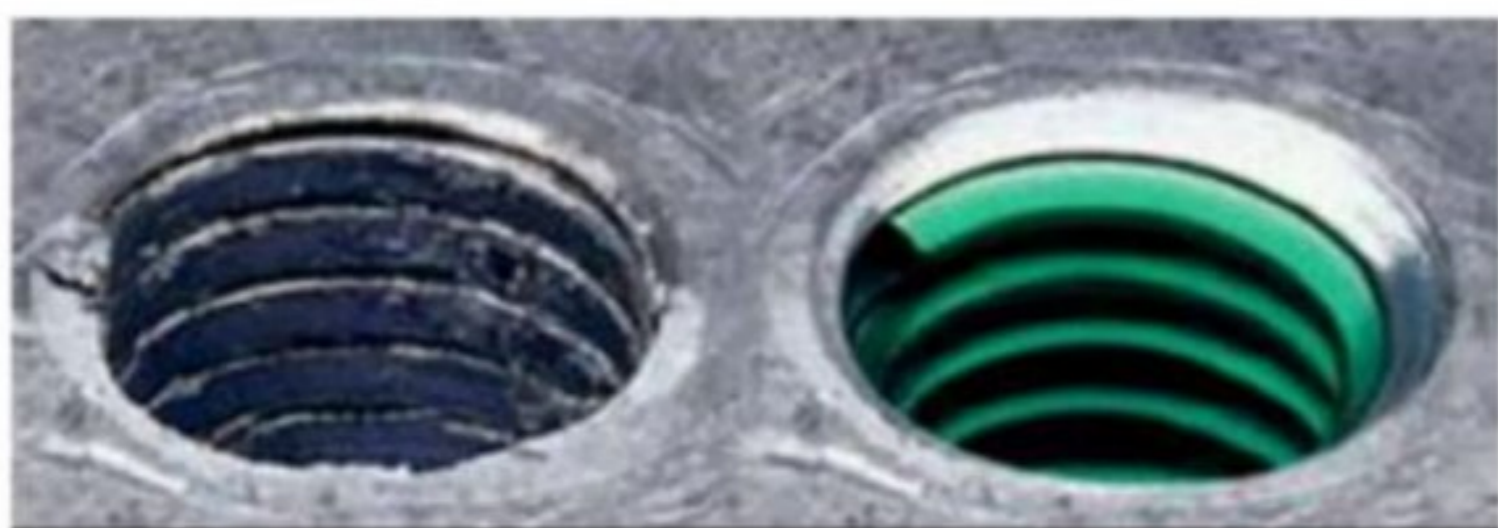

almacen\_ferrobrero@hotmail.com [¡envíanos tu cotización!](#)



## PUNTO GIRATORIOS



## PUNTO GIRATORIOS

## PUNTO GIRATORIOS



**MICROMETRO EXTERIOR**



**CALIBRADOR DE PROFUNDIDAD**

**TRANSPORTADOR GRADOS**



**CALIBRADOR TELESCOPICO**



**MICROMETRO DE CILINDRO**



**VERIFICADOR DE PROFUNDIDAD**





**CENTRO PUNTO  
AUTOMATICO**

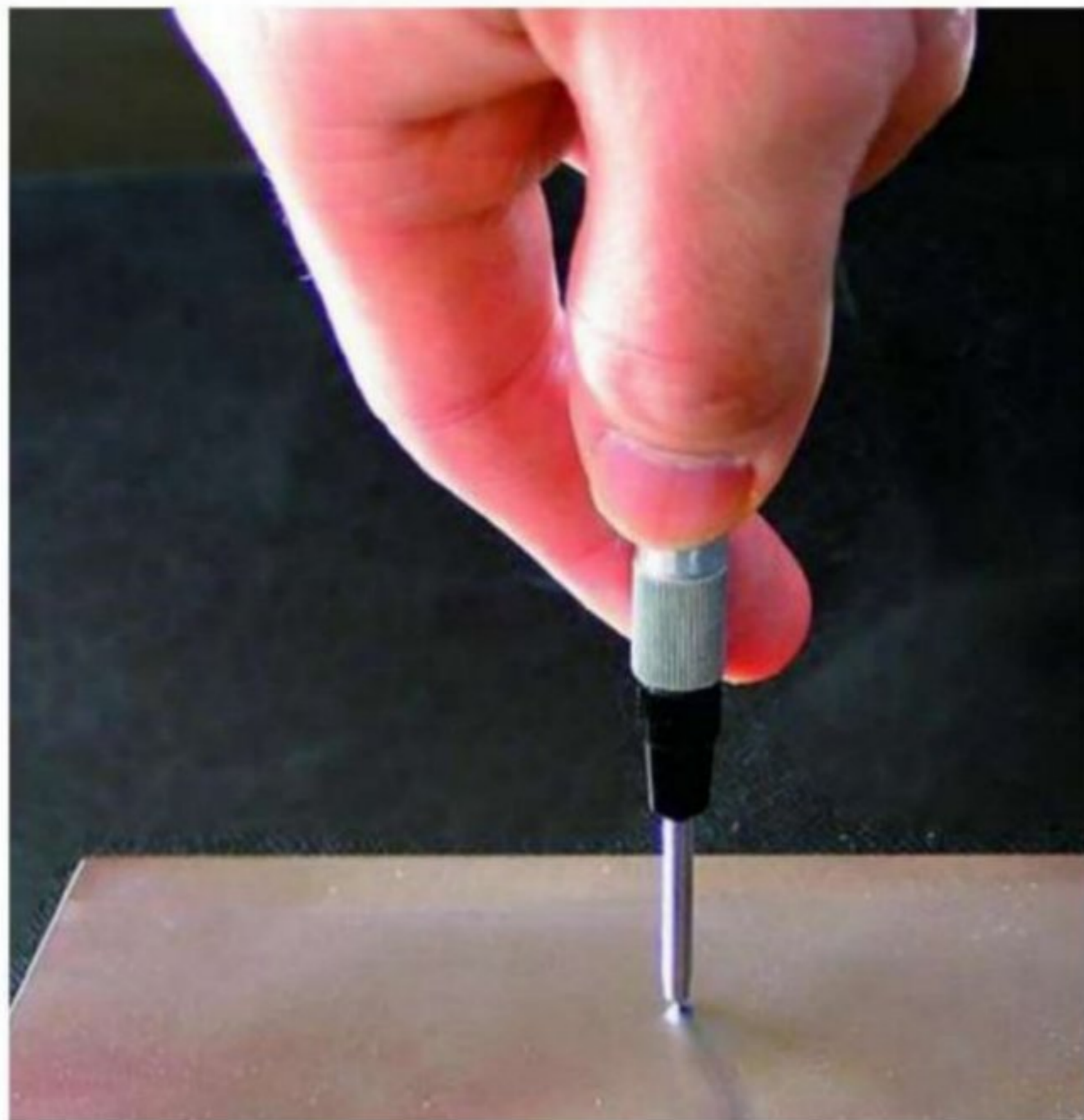

**RAYADOR P/METAL**



**MARCADOR  
DE  
PINTURA**

almacen\_ferrobrero@hotmail.com [¡envíanos tu cotización!](#)







## PRENSA DE CORDENADAS

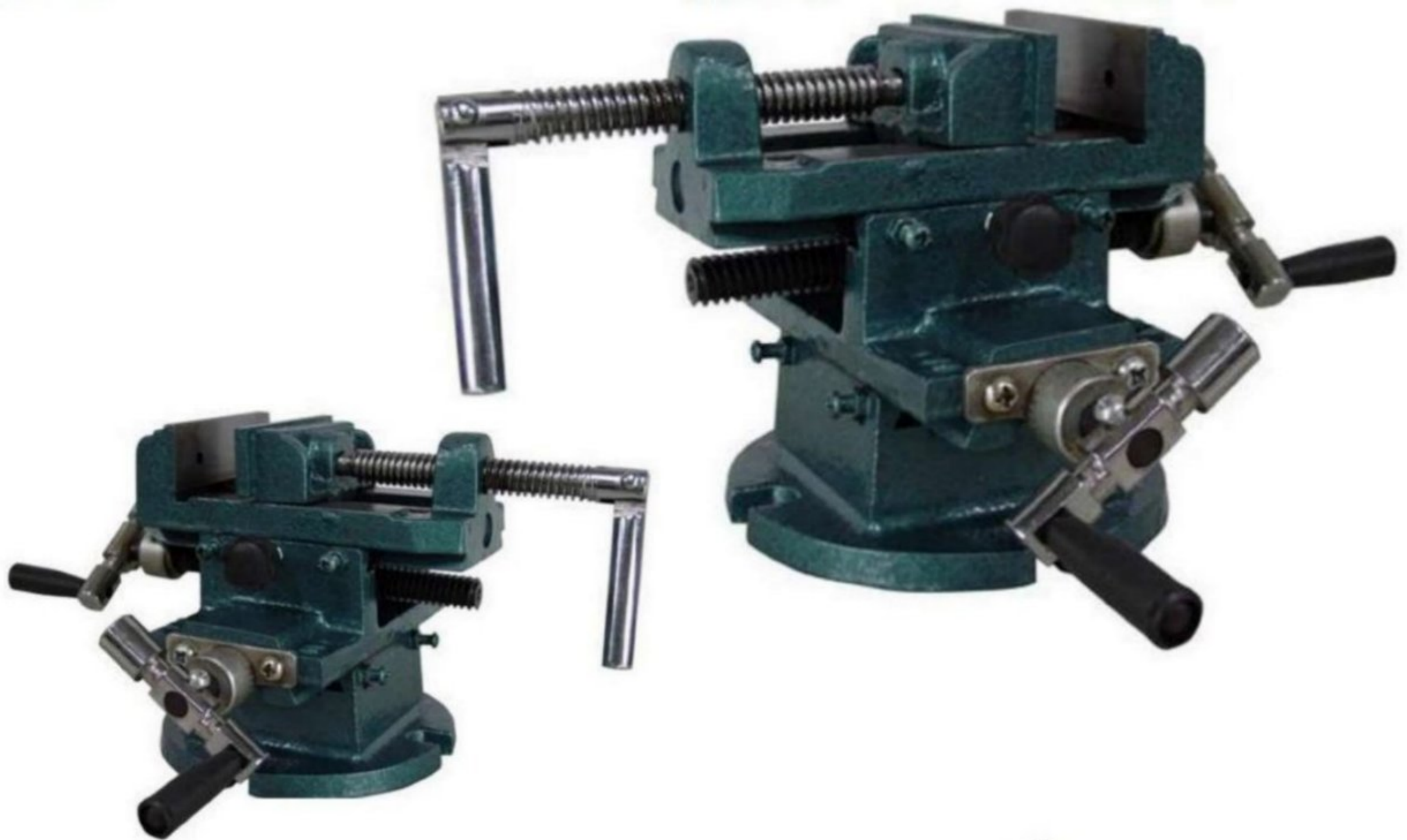

## TORRETETA DE CAMBIO RAPIDO

almacen\_ferrobrero@hotmail.com [envíanos tu cotización!](#)



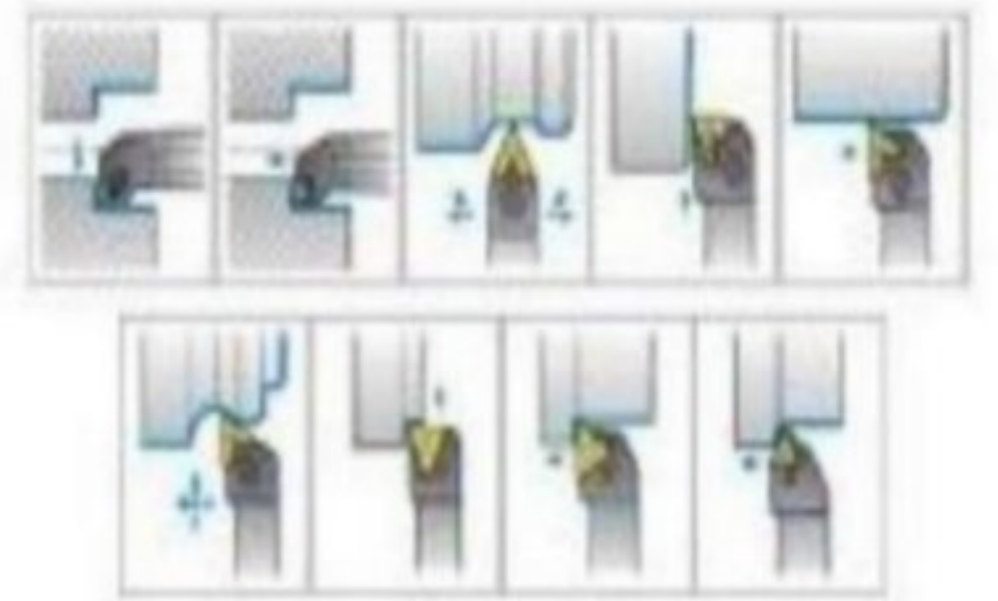
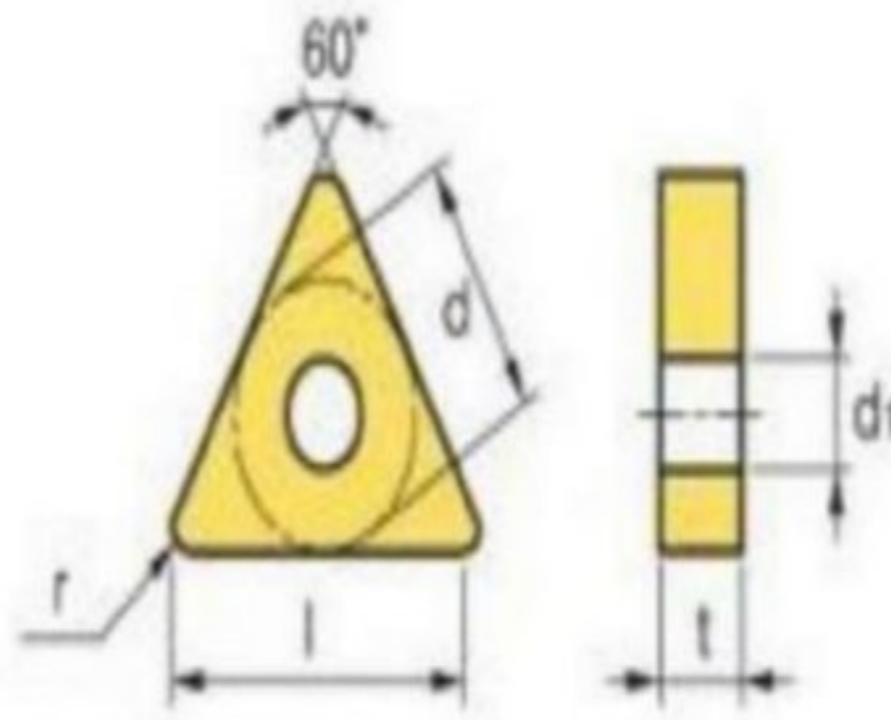

ØØ - Diámetro Mínimo Maquinado

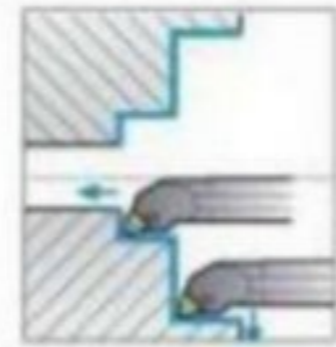
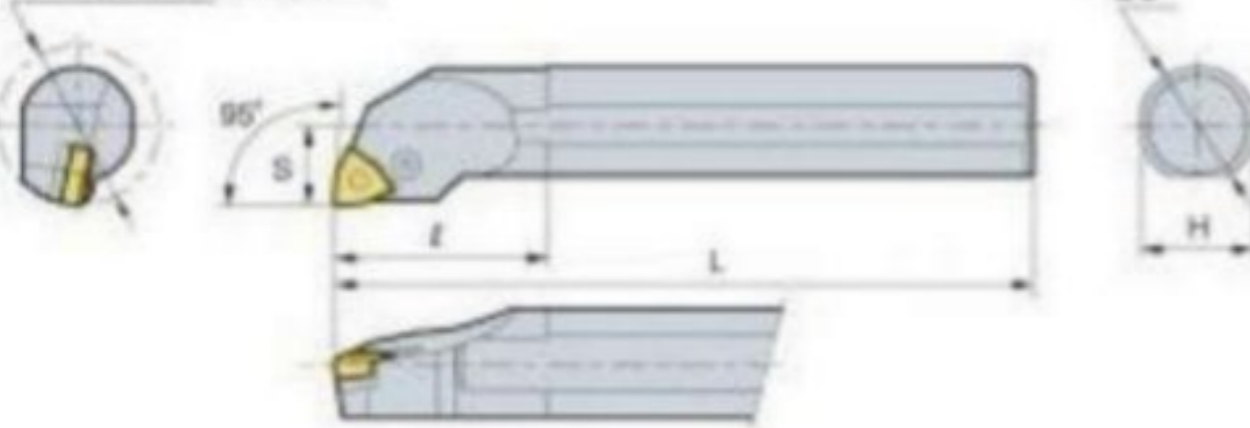





**BARRAS DE TUNGSTENO**



**BURILES REDONDOS  
TUNGSTENO**

almacen\_ferrobrero@hotmail.com **¡envíanos tu cotización!**





**Eurobit**  
TOOL GROUP  
ITALY

CUTTING TOOLS  
AND UNIVERSAL ACCESSORIES FOR POWER TOOLS  
FOR TRADE & INDUSTRY  
INNOVATIONS 2002-03



almacen\_ferrobrero@hotmail.com **¡envíanos tu cotización!**







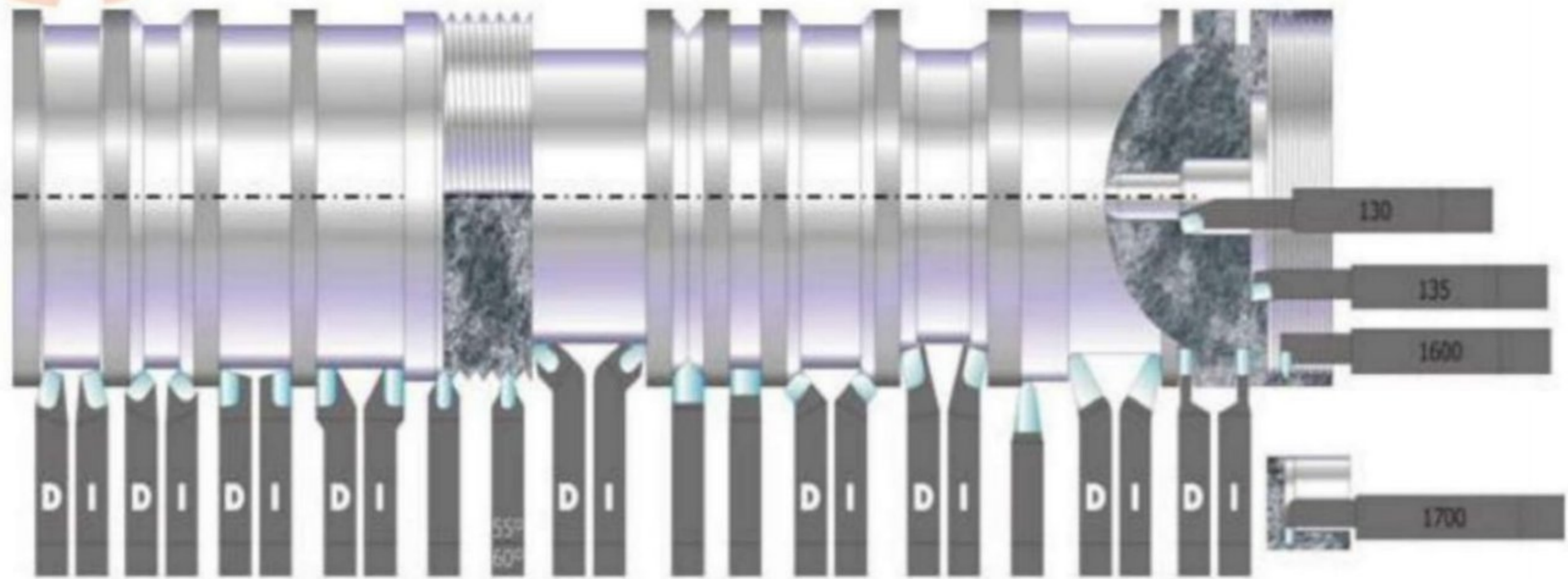

**PORTA LAMA**

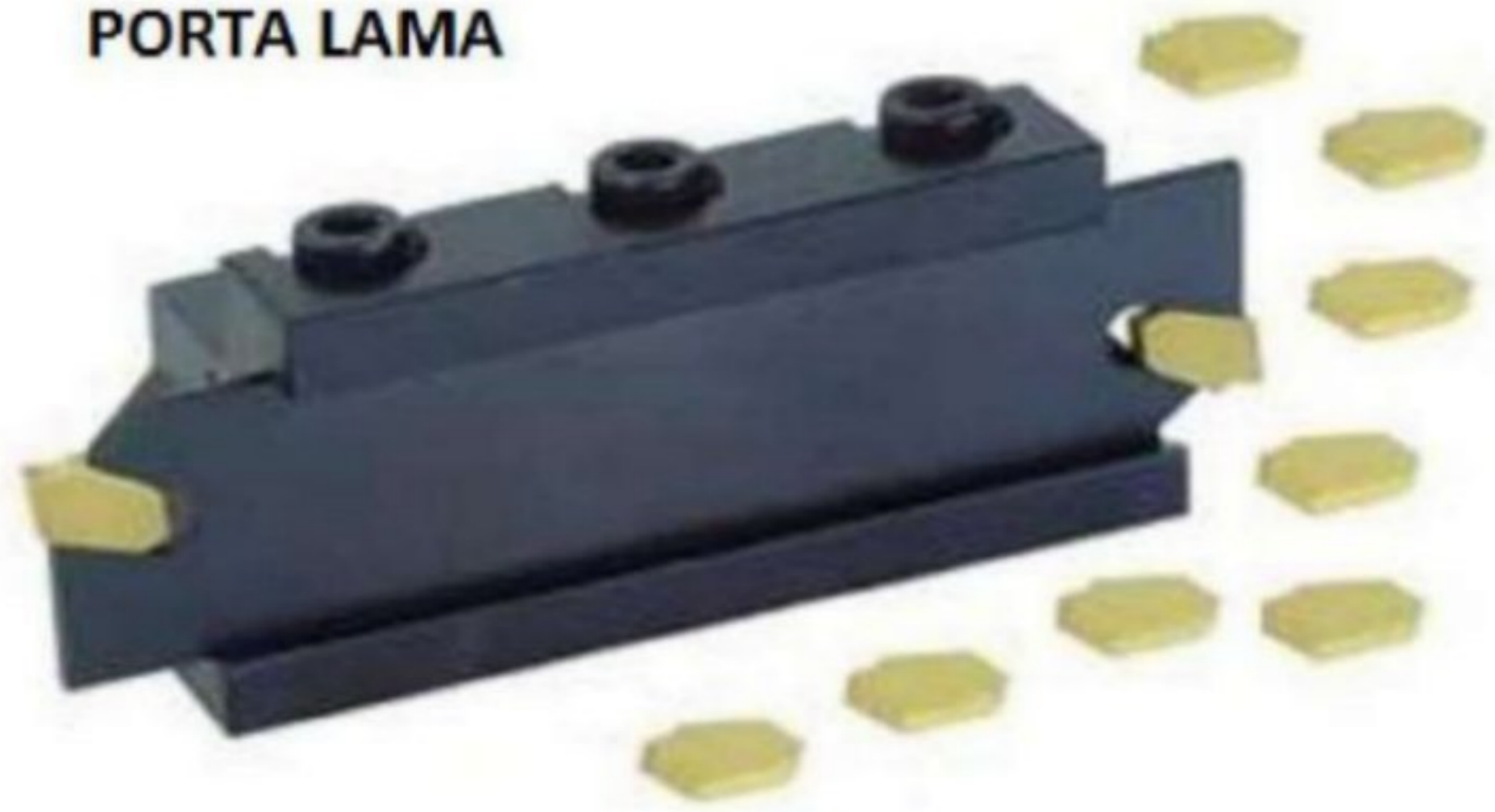

**PUNTO FIJO**

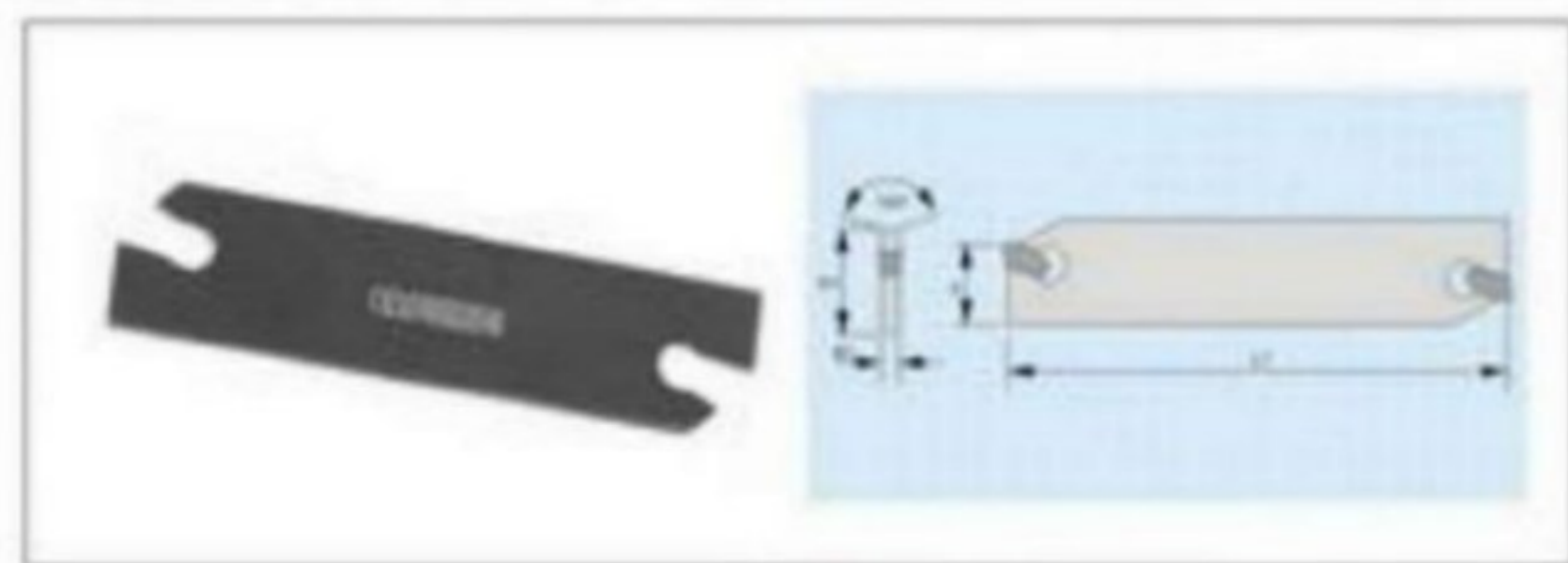
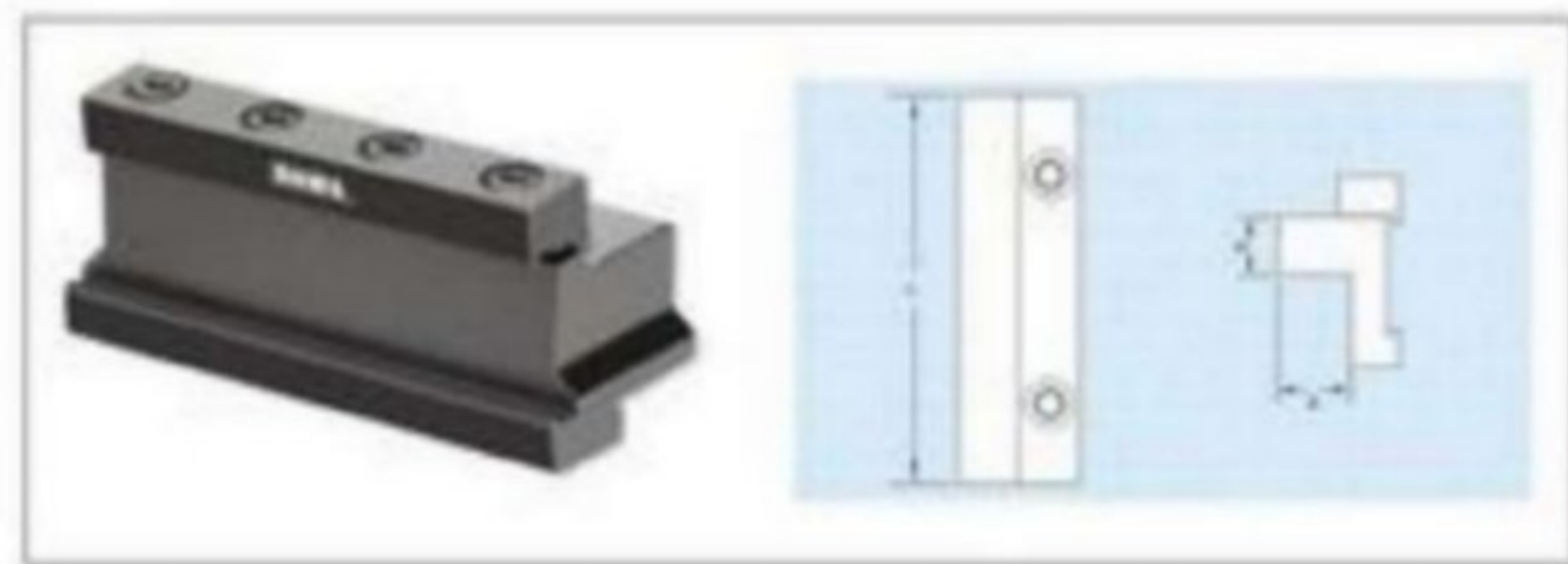

**PORTA CUCHILLA**



almacen\_ferrobrero@hotmail.com **¡envíanos tu cotización!**



